

Quick Review of Electricity

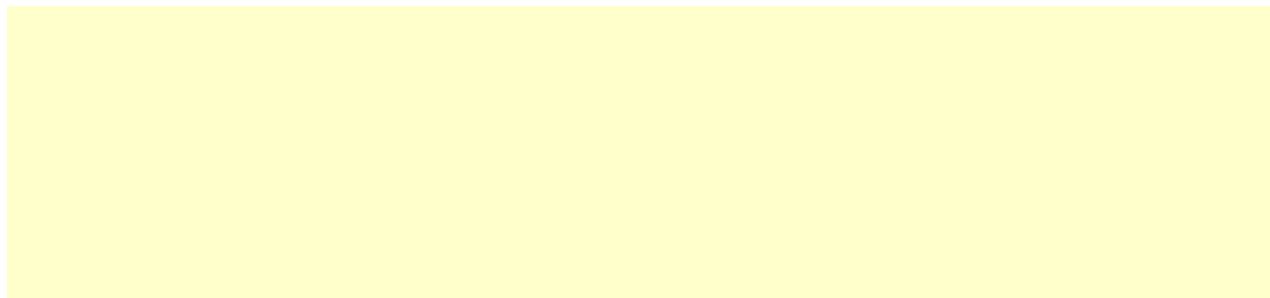

Power $P = \text{power} = \text{work performed per unit time}$

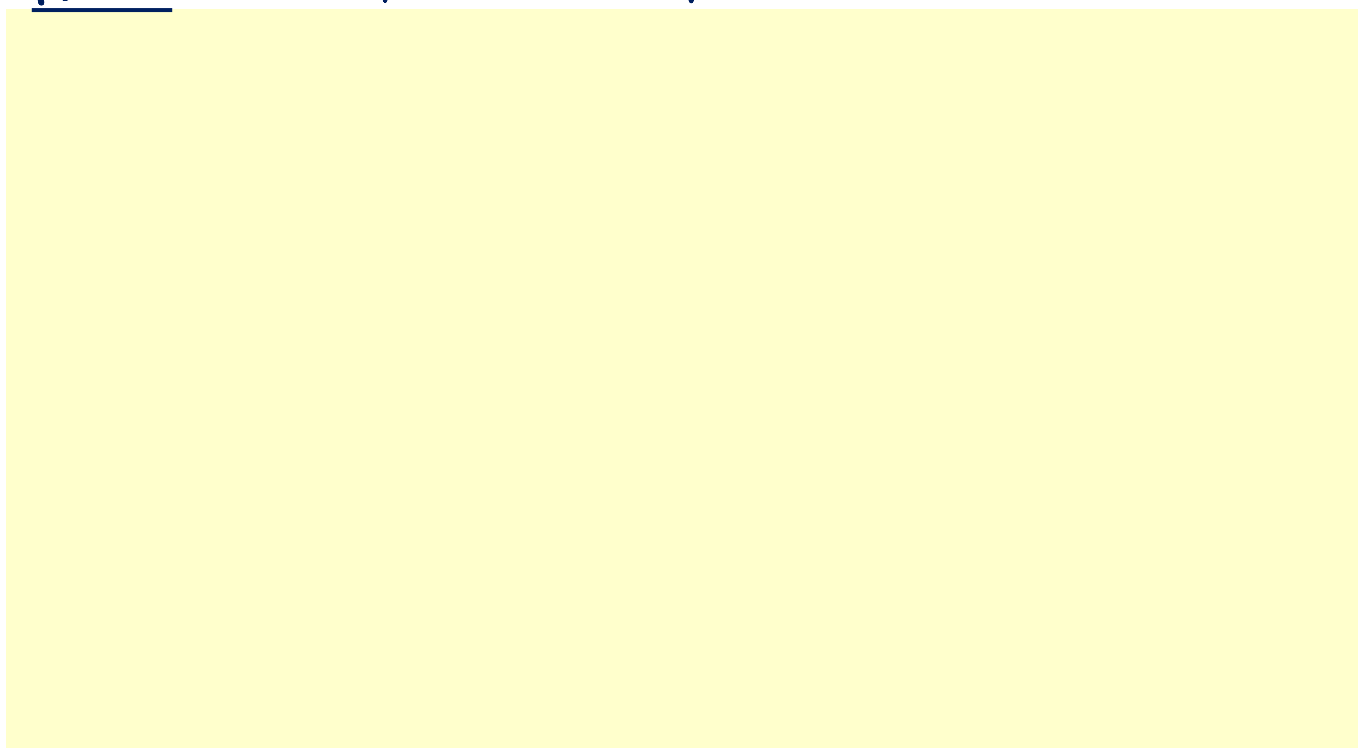

CLASS PROBLEM: If a D-cell battery supplies 2W of power to a small bulb, then find
(a) the current through the bulb, and
(b) the resistance of the bulb.

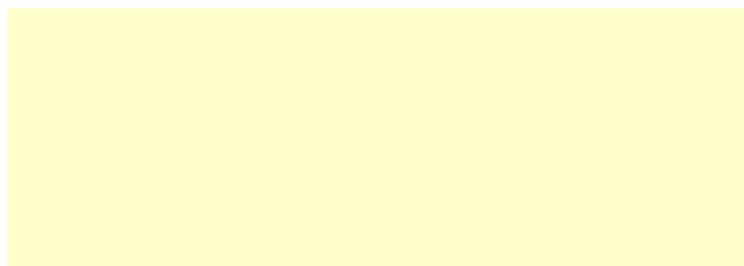
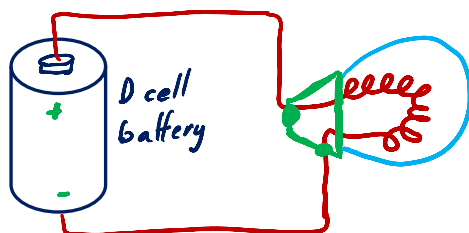

EQUIVALENT RESISTANCE

① Resistors in Series

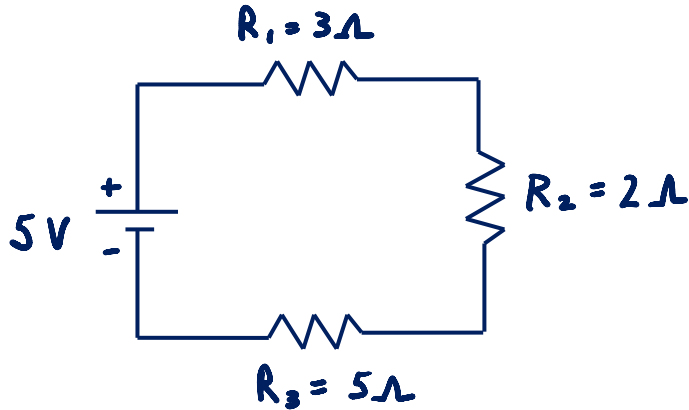

② Resistors in Parallel

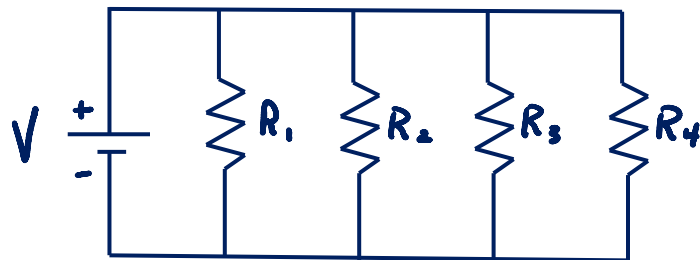

CLASS PROBLEM: Consider the circuit depicted below.

- What is the total current supplied to the resistors (the current that leaves the power source)?
- How much power is consumed by the resistors?

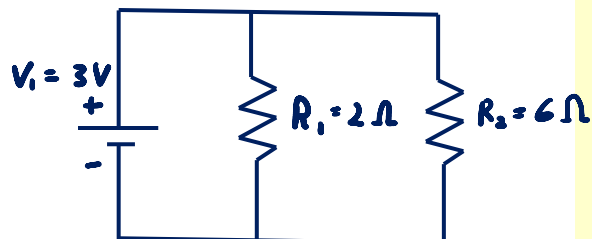

NOTE: Solve the previous problem using Mathcad before proceeding (solution is available on the website).

③ Combined series and parallel circuits

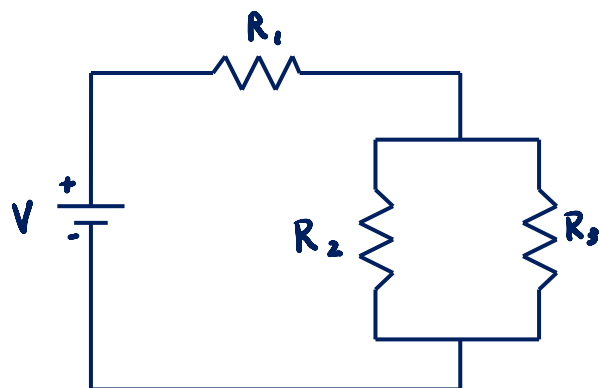

TIPS:

1. Combine adjacent series resistors.
2. Compute the equivalent resistance of each "bank" of parallel resistors.
3. Repeat steps 1 and 2 above until R_{eq} is found.

