

IMECE2007-43579

INCREASING EXPERIENTIAL LEARNING IN FRESHMAN ENGINEERING THROUGH A MICROFABRICATION PROJECT

H. Hegab
Mechanical Engineering Program
Louisiana Tech University
Ruston, LA 71272
hhegab@latech.edu

D. Hall
Mechanical Engineering Program
Louisiana Tech University
Ruston, LA 71272
dehall@latech.edu

ABSTRACT

A hands-on microfabrication project was developed and piloted for Louisiana Tech's integrated freshman engineering curriculum. The project involves the design and fabrication of a simple nickel resistance temperature detector (RTD). The project is part of a series of hands-on projects being developed for the freshman engineering curriculum as part of a "Living with the Lab" concept that utilizes the BASIC Stamp Board-of-Education (BoE-bot) kit (a microcontroller-based robotics kit) to increase experiential learning. The project was piloted in two sections of a freshman engineering course taken by all engineering majors at Louisiana Tech. The temperature sensor was used by the students as part of a control systems project to monitor and control the temperature and salinity of a water tank. The project included the direct application of fundamental engineering topics as well as applied technical skills that are part of the freshman curriculum. It also provided an opportunity to introduce the students to some common microfabrication techniques. The RTDs were fabricated using optical lithography and etching of a nickel coated Kapton® film. Students designed the geometry of the RTD based upon the resistivity of nickel. They created masks patterns using a commercial CAD package. They participated in a lab demonstration of the processing steps in performing photolithography to create the RTD pattern on the nickel coated Kapton® film. They then used their BoE-bot microcontrollers to measure the resistance of their RTD sensors and to calibrate the sensors. The project is being refined to be implemented this next academic year for the entire freshman engineering student body.

INTRODUCTION

Engineering faculty who are committed to educational reform have long since realized that passive lecture-based

instruction should be replaced by active, integrative project-based learning [1-2]. The movement toward project-based freshman engineering curricula began in the 1990s due in large part to the NSF Engineering Education Coalitions [3-6]. This movement towards hands-on freshman engineering programs with a significant design component continues today at universities across the country [7-9]. The vast body of literature on the subject clearly shows the benefits of incorporating project-based instruction with design early and often within engineering curricula [1-11].

In 1998 the College of Engineering and Science moved to an integrated engineering curriculum based on the educational practices of the NSF Educational Coalitions. Our freshman integrated curricula is shown in Table 1. The freshman integrated courses are taken in "blocks" so that classes of 40 students share the same mathematics, science and engineering courses. The topics presented in the mathematics and science courses are coordinated with the topics presented in the engineering courses to motivate student learning and to provide for content overlap. The ENGR 12X courses include engineering fundamentals (circuits, materials balance, and statics), computer applications (Excel®, Mathcad® and SolidEdge®), statistics, engineering economics, teamwork, communication skills, and a design project. Results from establishing this freshman curriculum indicate that students who completed the integrated curriculum were better prepared for more advanced math and engineering courses [12].

With the falling prices of laptop computers, electronic components, and microprocessors it is now possible for each engineering student to own a complete laboratory with instrumentation and a design platform. Consequently, the college is in the process of establishing a project-based curriculum built around student-owned labs. Student ownership of the "laboratory" changes the way we can approach

engineering education, especially in lower-level classes where large numbers of students are involved. Student-owned labs can help motivate student learning, broaden the spectrum of projects and design topics that can be addressed, and provide a giant boost in experiential learning. Projects can be initiated in class and students can take their “lab” with them to continue to work on the project or investigate other aspects that could not be covered in class. Our major aim is to create innovative students with a can-do spirit through a project based curriculum where students repeatedly apply technology and fundamentals to solve problems. The new curriculum, called “Living with the Lab”, boosts experiential learning by putting the ownership and maintenance of the “lab” into the hands of the students. Each student purchases a robotics kit (Parallax Board of Education kit ~\$150) with a programmable controller, sensors, servos, and software to provide the basis for a mobile laboratory and design platform. The College has recently moved to requiring incoming freshman to own a laptop computer so purchasing the robotics kit is similar to purchasing a textbook for the course (no textbook is currently used in the course). Student-owned labs motivate student learning and broaden the spectrum of projects and design topics that can be addressed, thus facilitating innovation.

Fall Quarter		Winter Quarter		Spring Quarter	
Course	sch	Course	sch	Course	sch
ENGR 120	2	ENGR 121	2	ENGR 122	2
MATH 240	3	MATH 241	3	MATH 242	3
CHEM 100	2	CHEM 101/103	2 / 1	PHYSICS 201	3

Table 1. Freshman Engineering Curricula.

As part of this enhancement to our existing freshman curriculum, we are developing new hands-on projects that incorporate use of the robotics kits as well as provide students with fabrication and testing skills that introduce engineering fundamentals. An example of this is the “fish tank” project (see Figure 1) that is used in ENGR 121. Students control the salinity and temperature of the “fish tank” and learn to perform elementary material balance and conservation of energy calculations for their system. This project has been piloted for two years and students fabricate several of the components of the “fish tank” such as machining a brass needle valve using a lathe. Which components are fabricated has been varied from year to year. In the most recent course offerings this past year, each student team fabricated their own miniature centrifugal pump in ENGR 120 and used micromanufacturing processes to build their own resistance temperature detector (RTD) in ENGR 121. There were several motivating factors for including a microfabrication project in the freshman engineering curriculum. One was to introduce students to the engineering design and fabrication of a sensor. Fabrication of the temperature sensor also offers a perfect opportunity for sensor calibration, which requires data analysis and linear regression and reinforces fundamental topics in electrical engineering that

fit very well with the course content. This paper focuses on the RTD project and its implementation.

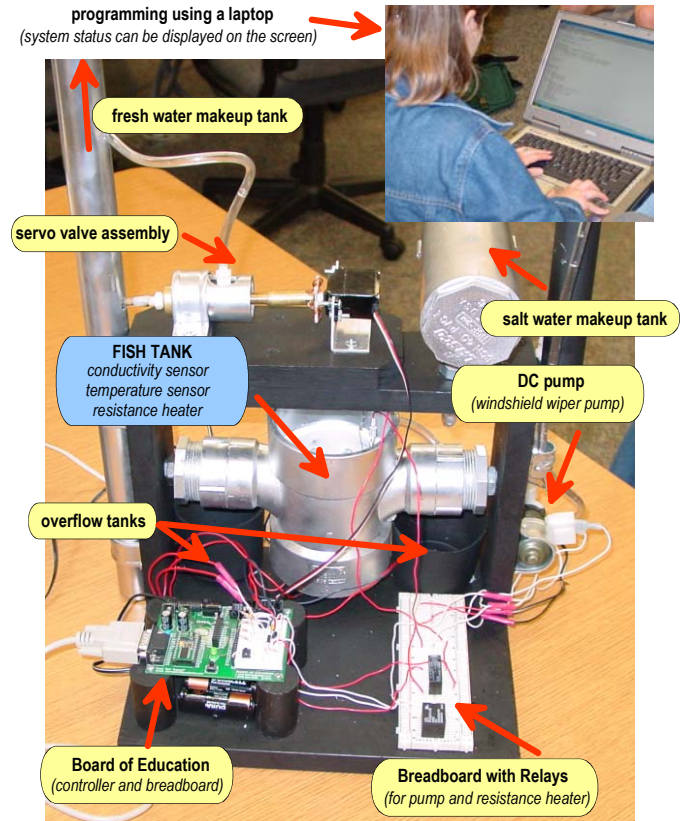

Figure 1. A student-built “fish tank”.

RTD PROJECT

Microsystems and nanotechnology are very diverse fields of application that cut across traditional disciplines and present an opportunity to bring students together from these disciplines to learn in a stimulating, interdisciplinary environment. Louisiana Tech has developed a strong research focus in the fields of micro and nanosystems that has emanated from research center in these fields, the Institute for Micromanufacturing. Louisiana Tech University also has a number of degree programs in micro and nanotechnology ranging from the undergraduate to graduate level [13]. The College recently produced its first graduate with a B.S. in Nanosystems Engineering. As such, it was desirable to integrate a micro/nano component to the students’ design project experience in the freshman curriculum. A nickel resistance temperature detector was selected for this purpose since it would facilitate many of the objectives of the freshman engineering curricula such as providing a hands-on project that could reinforce engineering fundamentals. As part of this project, students design and learn to fabricate a temperature sensor using semiconductor micromachining techniques. Students were taught the design and fabrication processes for creating a nickel RTD as described below.

- Students designed the geometry of the nickel resistor pattern. This required students to perform some simple design calculations utilizing concepts such as resistivity and Ohm's law.
- Students created a mask pattern using a CAD package (SolidEdge) to fabricate their sensor. They are taught to use this CAD package for other parts of the freshman engineering curriculum. This particular use introduces them to some of the drafting abilities of the package.
- Students learned the overall semiconductor fabrication processes used which are further described below.
- Students examined the resulting RTD geometry using optical microscopy. This inspection provides an opportunity for students to recognize the variations that may result between a product design and an actual manufactured product.
- Students tested their resistance temperature sensor by creating an RC circuit using the BoE-bot kits and then calibrated it for their fish tank project.

The project was implemented over four class periods in the ENGR 121 course. The course meets twice a week for 1 hour and 50 minute periods. It is a 2 semester credit hour course and considered to be a combination of lecture and laboratory. Students were provided an overview of the project that introduced them to the general steps of microfabrication that were needed for the project and provided them some background information and theory about temperature measurement. The RTDs were made using optical lithography and etching of a nickel coated polyimide film (Kapton®). Figure 2 provides a photograph of an example RTD that was fabricated. The polyimide film was 127 μm (5 mils) thick and was coated with a 900 nm thick film of nickel. In developing the project, it was found necessary to mount the film on to glass slides to provide some structural support for handling purposes. The overall RTD fabrication steps were

1. Prepare the substrate for spinning
2. Spincoat the substrate with photoresist
3. Soft bake
4. Apply a photomask of each student group's RTD pattern design and expose to UV light
5. Develop the photoresist
6. Rinse and dry
7. Hard bake
8. Etch exposed nickel
9. Remove photoresist
10. Connect leads
11. Cover the sensor with Kapton® tape

As a first homework assignment students were required to determine an appropriate pattern (length and width) of nickel for a given thickness to produce a 100 Ω resistor and to predict the change in resistance with temperature (i.e., sensitivity) of

their design. They were also given some general design guidelines (i.e., minimum resistor widths) based upon the limitations of manufacturing techniques being used to guide their design selection since there are an infinite number of solutions (lengths and widths) that could be selected. At the next class meeting they were given a brief tutorial on the drafting component of a CAD package that is used in the freshman engineering curriculum. They were then assigned homework to create the pattern for their particular RTD mask design (see Figure 3). During this class meeting, they were also provided a demonstration of the microfabrication processes involved.

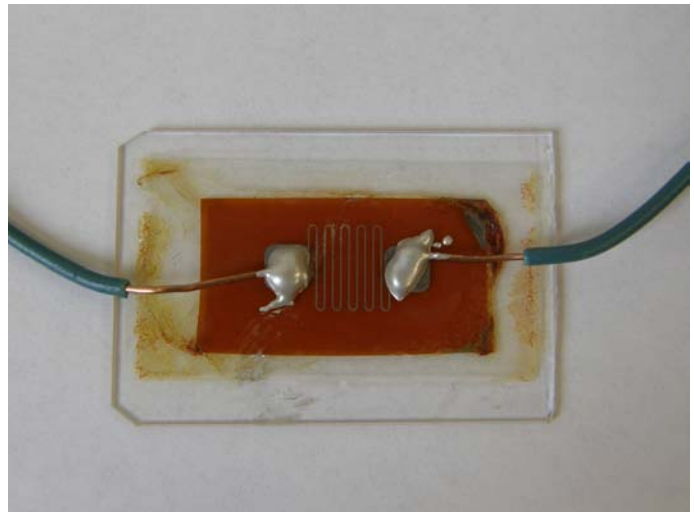

Figure 2. Fabricated RTD sensor.

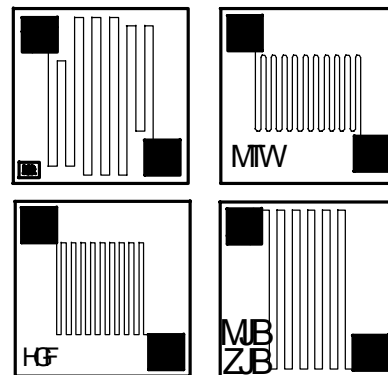

Figure 3. Student created RTD design patterns.

For this pilot year, individual RTDs were fabricated for student teams of two while teams of four were used for the overall "fish tank" project. This same approach will likely be used for the full implementation of the project this next academic year. This approach provided each "fish tank" team two RTD sensors in case problems were encountered in their design or its fabrication and testing. Approximately 90% of the student teams produced an RTD sensor that had some

functionality (i.e., had a measurable resistance). More than half of the teams produced an RTD sensor which was capable of providing an adequate temperature measurement for the “fish tank” project. Reasons for some of the unsuccessful RTDs varied from processing issues such as dust particles, cracking of the nickel films, poor connections at RTD leads, and some incorrect designs (i.e., student mistakes in design calculations). The most significant failure mode was cracking in the nickel film and this primarily was an issue of using a flexible substrate (Kapton® film). The actual optical lithography fabrication was handled by a trained undergraduate student. For our next phase of implementation the potential of scaling lab resources to fully implement fabrication by students is being considered. The required equipment for the fabrication processes includes a photoresist spinner, a UV exposure station, and a hot plate, and a fume hood for the etching process. Plans are also to include one additional class period for inspecting the RTDs after fabrication. Shop microscopes with measurement reticles have been obtained which should allow the students to make measurements of the width and lengths of the RTD patterns they produced. This additional step in the project will allow students to reanalyze their designs based upon how their sensor was actually fabricated.

During the final class meeting, the students attached lead wires to their sensors and calibrated the sensors using their BoE-bot robot kits. Students learn in the previous ENGR 120 course to use the programmable microcontrollers in the BoE kits to measure resistances using an RC timing circuit (see Figure 4). The circuit allows for variable resistance measurements by measuring the time it takes a capacitor to charge. Integrating the RTD sensor with their BoE microcontroller provides the students with a more open-ended opportunity to design their own RC timing circuit to measure a variable resistance. Students must consider how to size the capacitor and resistor, R_1 , to accurately measure the range resistances they expect to encounter. To calibrate their RTD sensors, the students used a heated water bath controlled with a hot plate. They obtained several data points of temperature versus RTD resistance from room temperature up to approximately 50°C. While uncertainty and accuracy were not high priorities for this calibration exercise, commercial RTD probes with accuracies of $\pm 0.1^\circ\text{C}$ that work with the hot plates were used as their reference temperatures. A calibration test setup with a BoE-bot robot kit is shown in Figure 5.

CONCLUSIONS

This hands-on microfabrication project was well received by the students and worked well in its first pilot with two class sections of 20 and 14 students, respectively. Issues that will need to be resolved for broader implementation will include scaling up the project for class section sizes of forty students. The authors are investigating simplifying the fabrication procedure to help accommodate this issue. Future plans also include developing video clips of fabrication steps to provide students additional guidance in the processing procedures as

well as to help reinforce safety precautions. Assessment tools for evaluating the impact of the project on experiential learning as well as the overall effect of the “Living with the Lab” concept on experiential learning outside of the classroom are being developed as well. The project will be introduced into six course sections of the freshman engineering program this next academic year. The project can be readily accomplished by freshman engineering students and provides opportunities for students to design a sensor using engineering fundamentals while learning about microfabrication processes.

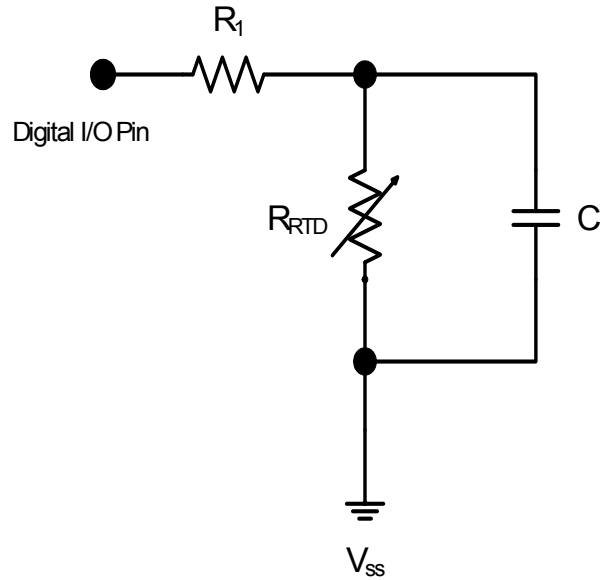

Figure 4. RCTime circuit.

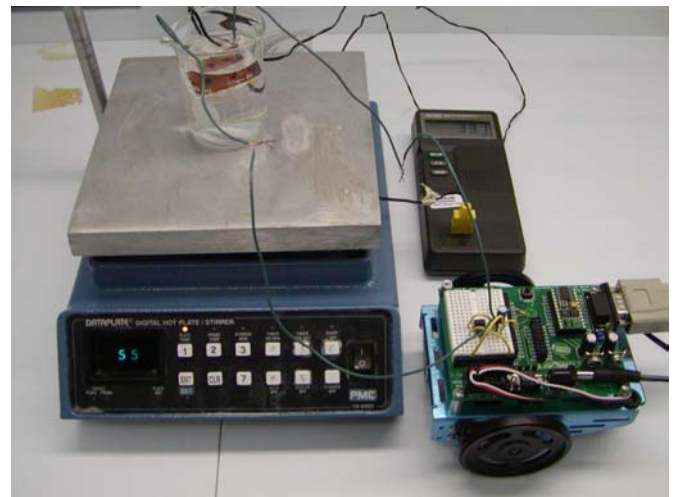

Figure 5. RTD Calibration test setup.

ACKNOWLEDGMENTS

Authors wish to acknowledge partial support of this work was provided by the National Science Foundation’s CCLI Program. Portions of this material were supported under grant

number DUE-0618288. Any opinions, findings, and conclusions or recommendations expressed are those of the authors and do not necessarily reflect the views of the National Science Foundation.

REFERENCES

[1] Splitt, F.G., "Systemic Engineering Education Reform: A Grand Challenge," The Bent of Tau Beta Pi, Spring 2003.

[2] Felder, R.M., "Changing Times and Paradigms," *Chemical Engineering Education*, **38** (1), 2004, 32-33.

[3] Richardson, J., Corleto, C., Froy, J., Imbrie, P.K., Parker, J., and R. Roedel, "Freshman Design Projects in the Foundation Coalition," *1998 Frontiers in Education Conference*, Tempe, Arizona, November 1998.

[4] Hanesian, D., and A.J. Perna, "An Evolving Freshman Engineering Design Program – The NJIT Experience," *29th ASEE/IEEE Frontiers in Education Conference*, November 10-13, San Juan, Puerto Rico, 1999. http://www.gatewaycoalition.org/files/Evolving_FED_Program.pdf

[5] Weggel, R.J., Arms, V., Makufka, M., and J. Mitchell, "Engineering Design for Freshman," prepared for Drexel University and the Gateway Coalition," February, 1998. http://www.gatewaycoalition.org/files/Engrg_Design_for_Freshmen.pdf

[6] Sheppard, S. and R. Jenison, "Examples of Freshman Design Education," *International Journal of Engineering Education*, **13** (4), 1997, 248-261.

[7] Carlson, L., Sullivan, J., Poole, S., and M. Picket-May, "Engineers as Entrepreneurs: Invention and Innovation in Design and Build Courses," *29th ASEE/IEEE Frontiers in Education Conference*, San Juan, Puerto Rico, 1999.

[8] ITL (Integrated Teaching Laboratory), University Colorado at Boulder, 2007, <http://itll.colorado.edu/ITLL/>.

[9] Hein, G.L. and S.A. Sorby, "Engineering Explorations: Introducing First-Year Students to Engineering," *31st ASEE/IEEE Frontiers in Education Conference*, Reno, Nevada, October 21.

[10] Carlson, L.W., and J.F. Sullivan, "Hands-on Engineering: Learning by Doing in the Integrated Teaching and Learning Program," *International Journal of Engineering Education*, **15** (1), 1999, 20-31.

[11] Cropley, D.H. and A. J. Cropley, "Fostering Creativity in Engineering Undergraduates," *High Ability Studies*, The

Journal of the European Council for High Ability, Carfax Publishing, Taylor & Franic Ltd. UK, **11** (2), 2000, 207-219.

[12] Nelson, J.D. and B. Schroder, "Establishing an Integrated Mathematics, Engineering, and Science Curriculum: Lessons Learned," *Proceedings of the American Society of Engineering Education Meeting*, Albuquerque, New Mexico, 2001.

[13] Hegab, H., "Microsystems and Nanosystems Engineering Education," *Commercialization of Micro and Nano Systems Conference*, August 27-31, St. Petersburg, FL, 2006.