

Form#: 52

Allowed materials include calculator (without wireless capability), pencil or pen.

Honor Statement: On my honor, I promise that I have not received any outside assistance on this exam (I didn't look at another student's paper, I didn't view any unauthorized written materials, I didn't talk or listen to another student, . . .).

_____signature

Dept.	Course #			Section (last 2 dig)	Exam Form
4	1	2	2		
0	0	0	0	0	0
1	1	1	1	1	1
2	2	2	2	2	2
3	3	3	3	3	3
4	4	4	4	4	4
5	5	5	5	5	5
6	6	6	6	6	6
7	7	7	7	7	7
8	8	8	8	8	8
9	9	9	9	9	9

H11	10-11:50 TR	Hall
H12	2-3:50 TR	Cronk
H13	12-1:50 TR	Swanbom
H14	8-9:50 TR	Hegab
001	2-3:50 MW	Swanbom
002	12-1:50 TR	Moller
003	8-9:50 TR	Evans

1 lb = 4.448 N
 1 in = 25.4 mm
 1 m = 3.281 ft
 g = 9.81 m/s²

- ★ also fill in **CWID**, **name** and **course (122)** . . . don't forget to black in bubbles
- ★ **you must show your work on problems that require calculations to receive credit**

Problem 1

(2 points) A PING))) sensor is mounted on your robot that is moving straight toward a wall. The Arduino records that the time of flight, or duration, of the sound wave (speed of sound = 1,126 ft/s) emitted then received by the PING))) sensor is 1480 μs. The distance from the robot to the wall is closest to...

- a. 5 in
- b. 6 in
- c. 7 in
- d. 8 in
- e. 9 in
- f. 10 in
- g. 11 in
- h. 12 in
- i. 13 in

Problem 2

(2 points) The three main groups of the 10 Faces of Innovation are

- a. T-shaped Personas, Learning Personas, and Organizing Personas
- b. T-shaped Personas, Anthropologists, and Organizing Personas
- c. Anthropologists, Collaborators, and Storytellers
- d. Learning Personas, Organizing Personas, and Building Personas
- e. Anthropologists, Hurdlers, and Caregivers
- f. Hurdlers, Collaborators, and Directors
- g. Vice Presidents, Middle Management, Engineers
- h. Anthropologists, Experimenters, and Cross-pollinators
- i. President, Vice Presidents, and Middle Management
- j. T-shaped Personas, Vertical Personas, and Lateral Personas

Problem 3

(2 points) Consider the design matrix using the Pugh Method for the remote controlled dog product used as an example in homework and class. What are the scores for Concepts 1, 2, and 3, respectively, and which concept should you develop based on the scores?

Criteria	Weight	Concept 1	Concept 2	Concept 3
Cost	3	(+)	(-)	(0)
Reliability	2	(-)	(+)	(+)
Max land area covered	1	(-)	(0)	(+)
Comfort for dogs	3	(0)	(-)	(+)
Ease of training	1	(+)	(0)	(+)
Score				

- a. +1, -3, +6, Concept 2
- b. +1, -3, +6, Concept 3
- c. 0, -4, +7, Concept 1
- d. 0, -4, +7, Concept 3
- e. +1, -4, +7, Concept 2
- f. +1, -4, +7, Concept 3
- g. +4, 0, -2, Concept 1
- h. +4, 0, -2, Concept 3

Problem 4

(2 points) The three learning personas are

- a. Experience architects, Caregivers, and Storytellers
- b. Set Designers, Caregivers, and Storytellers
- c. Anthropologists, Experimenters, and Cross-pollinators
- d. Hurdlers, Collaborators, and Directors
- e. Anthropologists, Hurdlers, and Caregivers
- f. Experimenters, Cross-pollinators, and Hurdlers
- g. Anthropologists, Directors, and Set Designers
- h. Cross-pollinators, Collaborators, and Storytellers
- i. Experimenters, Collaborators, and Experience Architects
- j. Cross-pollinators, Directors, and Caregivers

Problem 5

(2 points) Which of the following corresponds to the pins for the RF receiver XERE02A used in class for the robot maze challenge?

a. 1 – 5V
2 – data valid
3 – GND
4 – output D
5 – output B
6 – output C
7 – output A
8 – antenna

c. 1 – 5V
2 – 10 V
3 – 20 V
4 – output A
5 – output B
6 – output C
7 – output D
8 – antenna

e. 1 – 5V
2 – antenna
3 – GND
4 – output D
5 – output B
6 – output C
7 – 10V
8 – antenna

b. 1 – GND
2 – antenna
3 – GND
4 – output C
5 – output D
6 – output B
7 – output A
8 – data valid

d. 1 – 5V
2 – data valid
3 – GND
4 – 20V
5 – output B
6 – GND
7 – output A
8 – antenna

f. 1 – 5V
2 – antenna
3 – GND
4 – output A
5 – output B
6 – output C
7 – output D
8 – 10V

Problem 6

(2 points) Based on the course notes, which of the following statements is true?

- a. Mind maps are more “free-form” than concept maps
- b. Concept maps are more “free-form” than mind maps
- c. Mind maps are more “structured than concept maps
- d. Persona maps are used to find the “right” people for a project
- e. Concept maps usually have many doodles and pictures to convey ideas
- f. Neither mind maps nor concept maps aids in brainstorming
- g. Neither mind maps nor concept maps provides a visual record of thought process
- h. Neither mind maps nor concept maps shows connections among ideas

Problem 7

(2 points) Which of the following best describes the ADXL335 accelerometer that was discussed in class?

- a. 3-axis accelerometer measuring accelerations in the roll, pitch, and yaw directions
- b. 3-axis accelerometer measuring accelerations in the x, y, and z directions
- c. 3-axis accelerometer measuring accelerations in the roll, pitch, and z directions
- d. 3-axis accelerometer measuring accelerations in the roll, y, and pitch directions
- e. 3-axis accelerometer measuring accelerations in the x, pitch, and yaw directions
- f. 4-axis accelerometer measuring accelerations in the x, y, z, and roll directions
- g. 4-axis accelerometer measuring accelerations in the x, y, z, and pitch directions
- h. 4-axis accelerometer measuring accelerations in the x, y, z, and yaw directions
- i. 5-axis accelerometer measuring accelerations in the x, y, z, roll and pitch directions
- j. 6-axis accelerometer measuring accelerations in the x, y, z, roll, pitch, and yaw directions

Problem 8

(2 points) If gear A causes gear B to spin at a higher RPM, then

- a. the torque transmitted by gear B will be higher than the torque transmitted by gear A.
- b. the torque transmitted by gear B will be lower than the torque transmitted by gear A.
- c. the torque transmitted by gear B will be the same as the torque transmitted by gear A.
- d. there is not enough information to relate the torques of gears A and B.

Problem 9

(2 points) The five steps of the IDEO Design Process, in order, are

- a. Visualize new to the world solutions, Observe people in real life situations, Understand the problem, Implement new concept for commercialization, Evaluate and refine prototypes
- b. Evaluate and refine prototypes, Observe people in real life situations, Visualize new to the world solutions, Understand the problem, Implement new concept for commercialization
- c. Understand the problem, Observe people in real life situations, Visualize new to the world solutions, Evaluate and refine prototypes, Implement new concept for commercialization
- d. Implement new concept for commercialization, Understand the problem, Visualize new to the world solutions, Observe people in real life situations, Evaluate and refine prototypes
- e. Observe people in real life situations, Visualize new to the world solutions, Understand the problem, Implement new concept for commercialization, Evaluate and refine prototypes
- f. Observe people in real life situations, Understand the problem, Visualize new to the world solutions, Evaluate and refine prototypes, Implement new concept for commercialization
- g. Understand the problem, Visualize new to the world solutions, Observe people in real life situations, Evaluate and refine prototypes, Implement new concept for commercialization

Problem 10

(2 points) Which of the following statements is true?

- a. In class, we used the shear to bending the sheet metal.
- b. You do not need to wear glasses or safety glasses when operating the brake and shear.
- c. You cannot get cut by sheet metal.
- d. In class, we used the brake to cut the sheet metal.
- e. You should always remove the safety bar attachment in front of the shearing edge so that you can see what you are doing to the sheet metal.
- f. You should keep hands clear of the hand punch when making holes.
- g. Sheet metal is only good for making nameplates.
- h. We used Rosie rivets in class to attach our two sheet metal pieces together to form each nameplate.

Problem 11

(5 points) The x-component of the force shown below is closest to

- (a) 26.2 N
- (b) 31.0 N
- (c) 32.7 N
- (d) 47.8 N
- (e) 50.3 N
- (f) 54.0 N

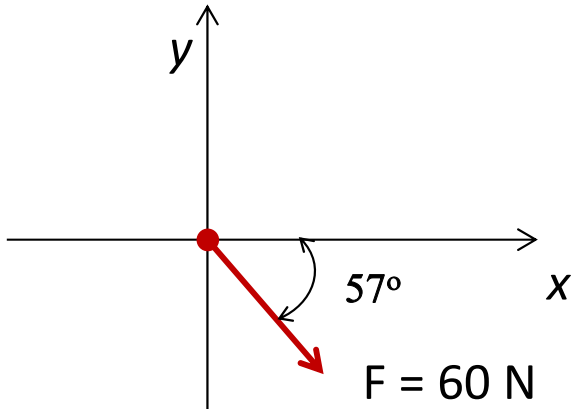

Problem 12

(5 points) The resultant of the system of forces shown below is closest to

- (a) 50.0 N
- (b) 62.0 N
- (c) 71.7 N
- (d) 83.8 N
- (e) 104.7 N
- (f) 145.5 N

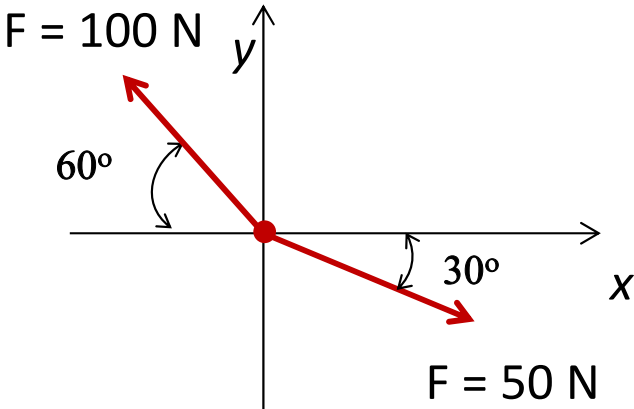

Problem 13

(5 points) The resultant of the system of four forces shown below is closest to

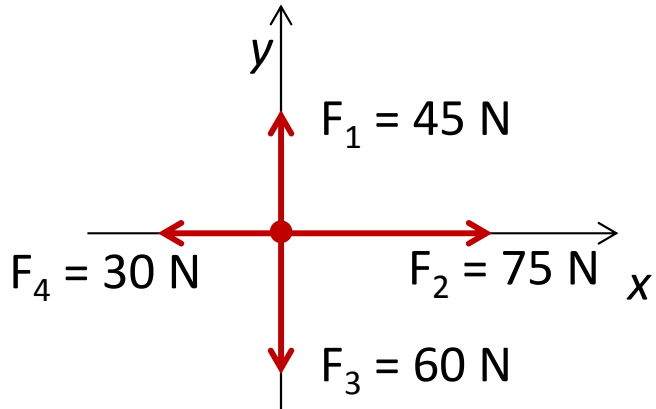

- (a) 42.4 N
- (b) 47.4 N
- (c) 87.5 N
- (d) 96.0 N
- (e) 101.7 N
- (f) 148.5 N

Problem 14

(5 points) For the system shown below (where $F_1 = 167$ lb, $\theta_1 = 15^\circ$, $\theta_2 = 62^\circ$, and $\theta_3 = 21^\circ$) the three forces can be considered to be in equilibrium when F_2 and F_3 are closest to...

- a. $F_2 = 135$ lb and $F_3 = 188$ lb
- b. $F_2 = 234$ lb and $F_3 = 355$ lb
- c. $F_2 = 111$ lb and $F_3 = 253$ lb
- d. $F_2 = 179$ lb and $F_3 = 216$ lb
- e. $F_2 = 117$ lb and $F_3 = 119$ lb
- f. $F_2 = 156$ lb and $F_3 = 391$ lb
- g. $F_2 = 203$ lb and $F_3 = 284$ lb
- h. not enough information

Note: The graphic below may not be drawn to scale.

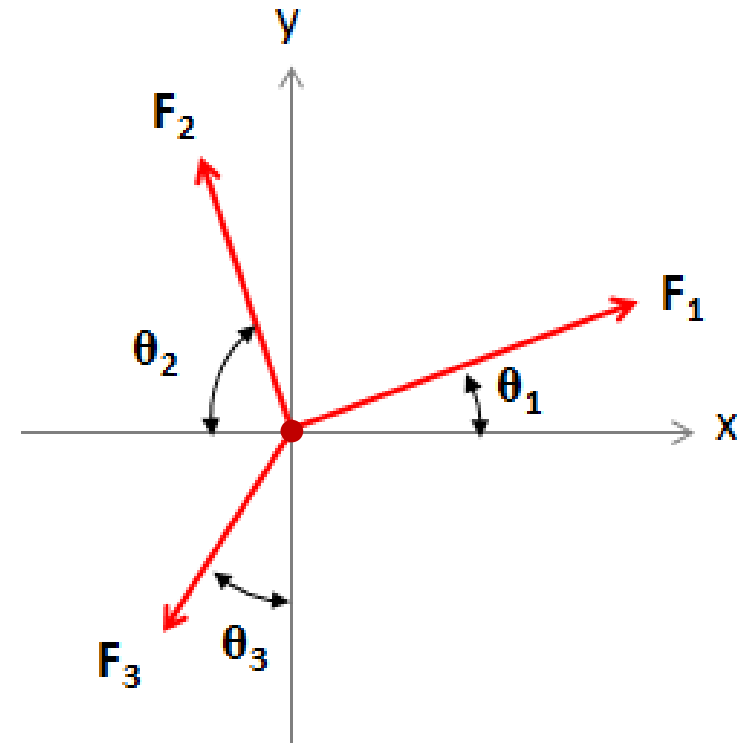

Problem 15

(5 points) A distance measuring wheel ($W_{\text{wheel}} = 5 \text{ lb}$, neglect the weight of the handle) is subjected to an angled force ($F_1 = 9.36 \text{ lb}$, $\theta_1 = 20^\circ$). If the angle of the ground is $\theta_2 = 47^\circ$ and the measuring wheel is considered to be in equilibrium, the magnitude of the normal force F_n is closest to...

- a. 3 lb
- b. 5 lb
- c. 7 lb
- d. 10 lb
- e. 12 lb
- f. 15 lb
- g. 17 lb
- h. 19 lb
- i. not enough information

Note: The graphic below may not be drawn to scale.

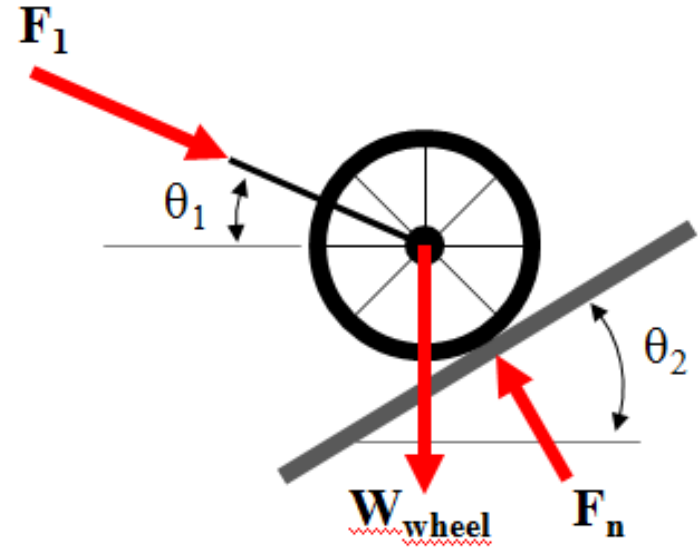

Problem 16

(5 points) A ladder ($d = 0.5 \text{ m}$ and $\theta = 25^\circ$) with a mass of 16 kg (lumped at the center as shown) is subjected to a perpendicular force at point B ($F_B = 29 \text{ N}$). The moment about point A is closest to...

Note: From this perspective, assume a clockwise rotation to be positive and a counter-clockwise rotation to be negative.

- a. $-153 \text{ N}\cdot\text{m}$
- b. $-120 \text{ N}\cdot\text{m}$
- c. $-75 \text{ N}\cdot\text{m}$
- d. $-28 \text{ N}\cdot\text{m}$
- e. $28 \text{ N}\cdot\text{m}$
- f. $75 \text{ N}\cdot\text{m}$
- g. $120 \text{ N}\cdot\text{m}$
- h. $153 \text{ N}\cdot\text{m}$

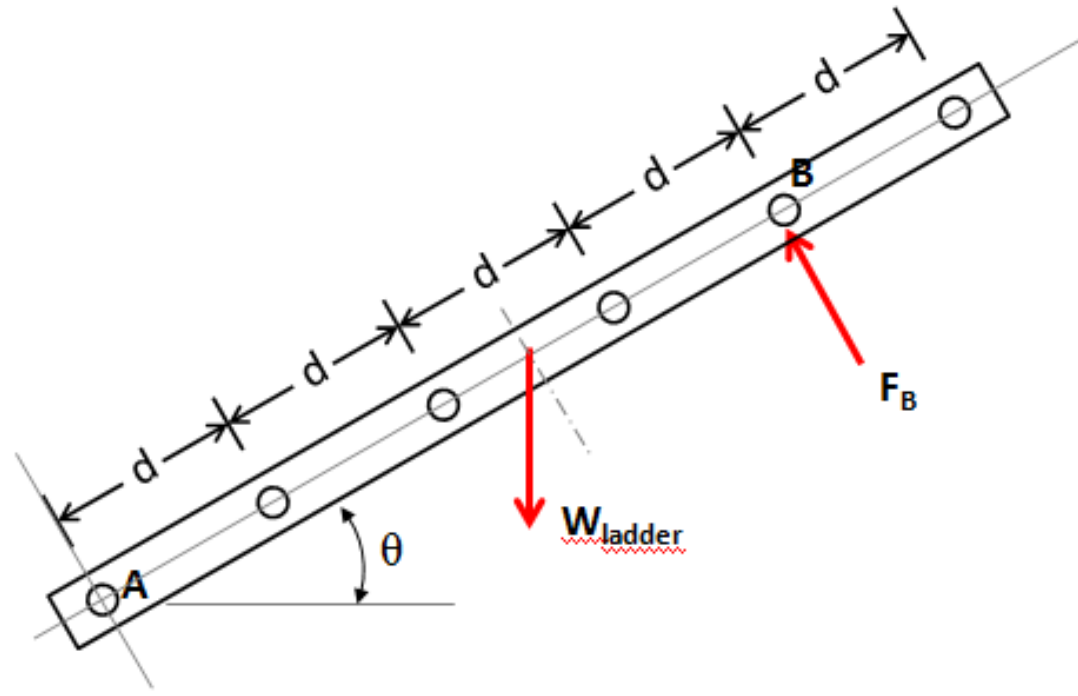

Problem 17

(5 points) A punching bag is subjected to a perpendicular force (where $h_1 = 5.5$ ft, $h_2 = 4.5$ ft and $F = 325$ N). The moment about point A created by the force is closest to...

$1\text{ft} = 12\text{in}$
 $1\text{in} = 2.54\text{cm} = 25.4\text{mm}$

Notes: From this perspective, assume a clockwise rotation to be positive and a counter-clockwise rotation to be negative. The graphic below may not be drawn to scale.

- a. -1788 N·m
- b. -1463 N·m
- c. -545 N·m
- d. -446 N·m
- e. 446 N·m
- f. 545 N·m
- g. 1463 N·m
- h. 1788 N·m

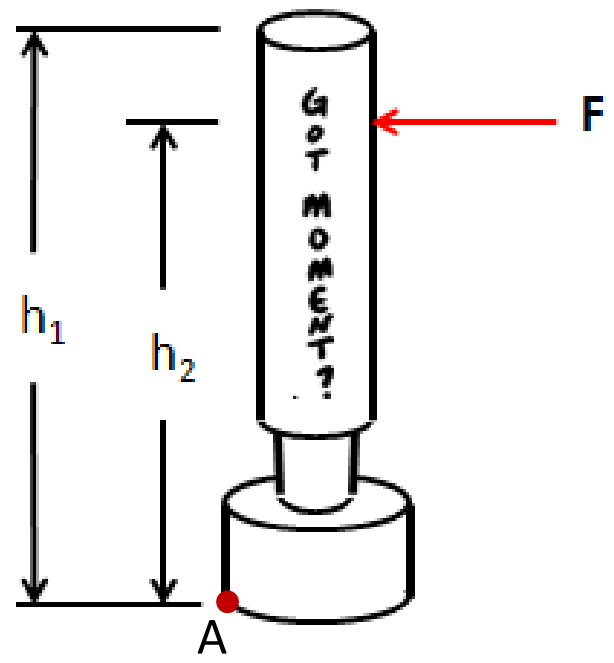

Problem 18

(5 points) A flower pot filled with dirt and flowers has a mass of 3.1 kg. If 2 L of water is added to the pot (with no leakage) and the force carried in cable AC is 28 N, the angle θ is closest to...

Notes: Assume the lengths of AB and AC are the same, and the flower pot's center of mass is aligned directly below the support and the ring at point A. The graphic below may not be drawn to scale.

- a. 26.7°
- b. 32.1°
- c. 37.4°
- d. 41.9°
- e. 46.3°
- f. 53.4°
- g. 58.5°
- h. 62.1°

$$\rho_{water} = \frac{1kg}{1L}$$

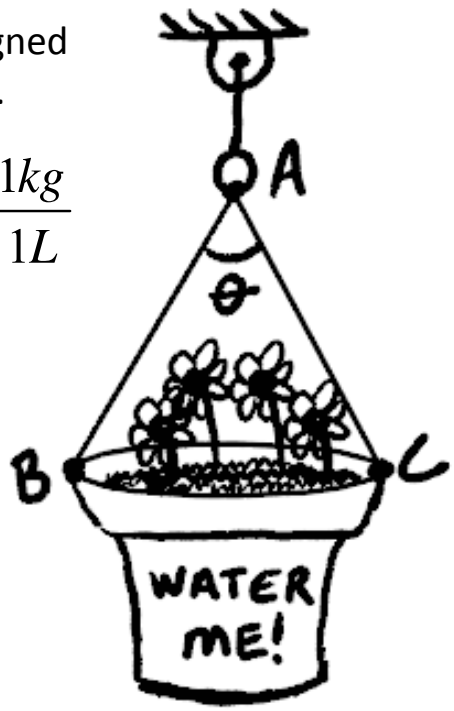

Problem 19

If the gear system shown here acts at a 100% efficiency, then what RPM will be required from the DC motor if the diameter d is 10 cm and the desired velocity for the movement of the weight is 50 cm/second?

- a. 84 RPM
- b. 157 RPM
- c. 954 RPM
- d. 1555 RPM
- e. 2387 RPM
- f. 2941 RPM
- g. 7423 RPM
- h. 10101 RPM

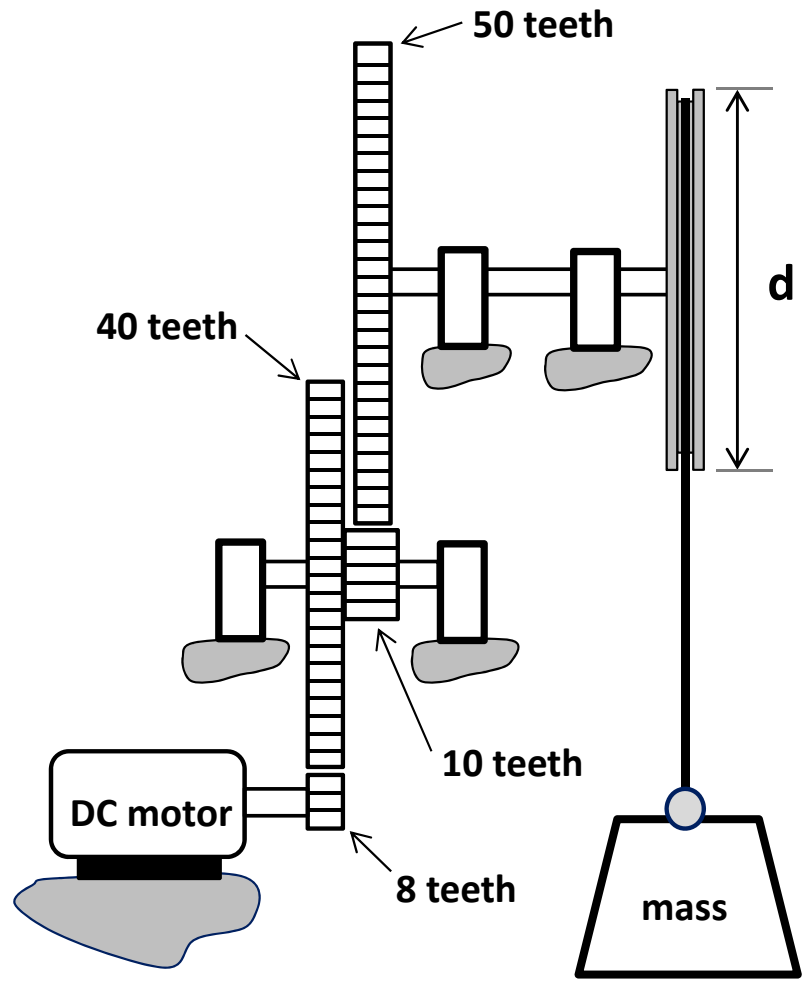

Problem 20

(5 points) A DC motor connected to a 18V power supply draws 5 A while powering a weight lifting device. Assuming a system (motor/gear train) efficiency of 65%, the speed at which the 60 kg mass is lifted is closest to . . .

- a. 0.10 m/s
- b. 0.24 m/s
- c. 0.98 m/s
- d. 1.50 m/s
- e. 4.25 m/s
- f. 6.54 m/s

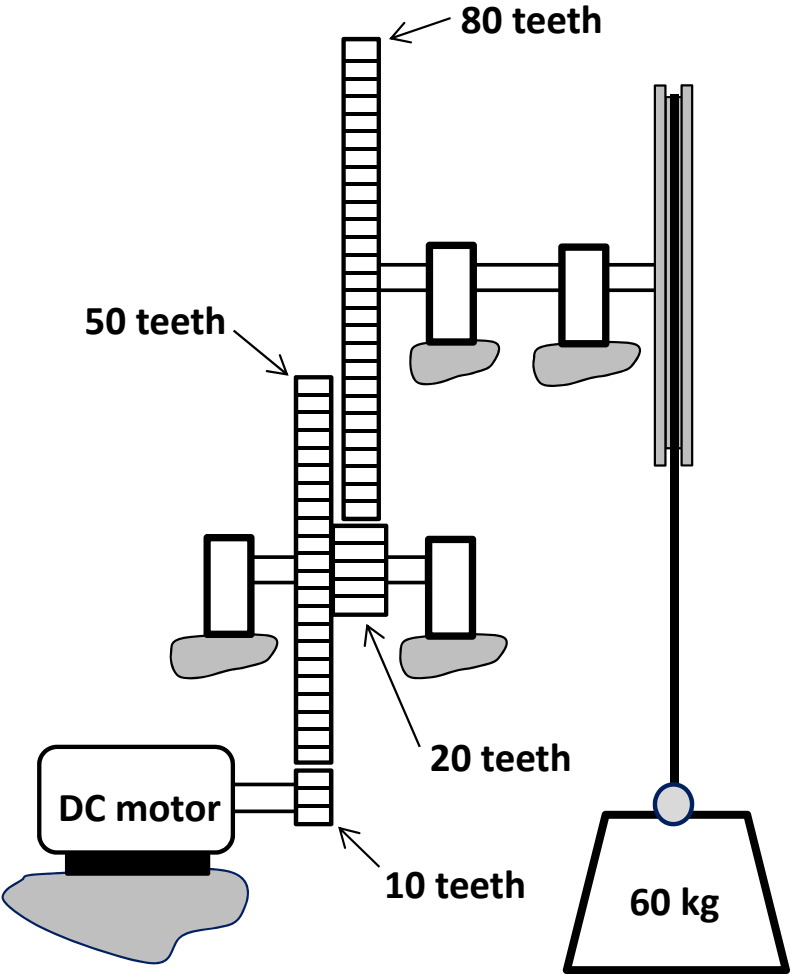

Problem 21

(5 points) When the beam shown contacts the support at C, there is 95 lb of compressive force in the spring.

The reaction at C is closest to:

- a. 188.1 lb
- b. 205.1 lb
- c. 221.2 lb
- d. 237.9 lb
- e. 254.2 lb
- f. 270.6 lb
- g. 287.0 lb
- h. 303.6 lb
- i. 319.8 lb

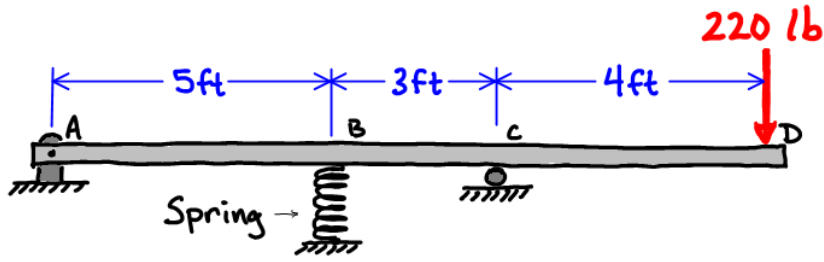

Problem 22

(5 points) The force carried by a hydraulic ram can be measured by measuring the hydraulic pressure in the ram and multiplying by the area of the piston head. The pressure in the ram shown is measured to be 110 psi (1 psi = 1 lb/in²), and the piston head diameter is 1.5 inches. The weight of the crate of alligator meat is closest to:

- a. 119 lb
- b. 126 lb
- c. 132 lb
- d. 139 lb
- e. 145 lb
- f. 151 lb
- g. 158 lb
- h. 164 lb
- i. 171 lb

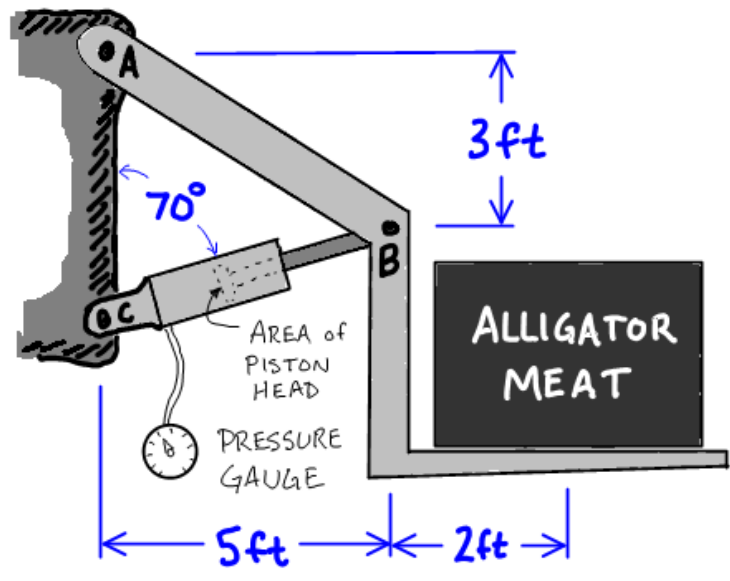

Problem 23

(5 points) In the motor/gearbox systems shown, the smaller spur gear is driven by a 24 V DC motor that draws 3 A of current while lifting a 100 N weight. If the system efficiency is 75%, the length of time it will take to lift the weight 2 meters is closest to . . .

- a. 0.9 seconds
- b. 1.9 seconds
- c. 2.1 seconds
- d. 2.8 seconds
- e. 3.7 seconds
- f. 18.2 seconds

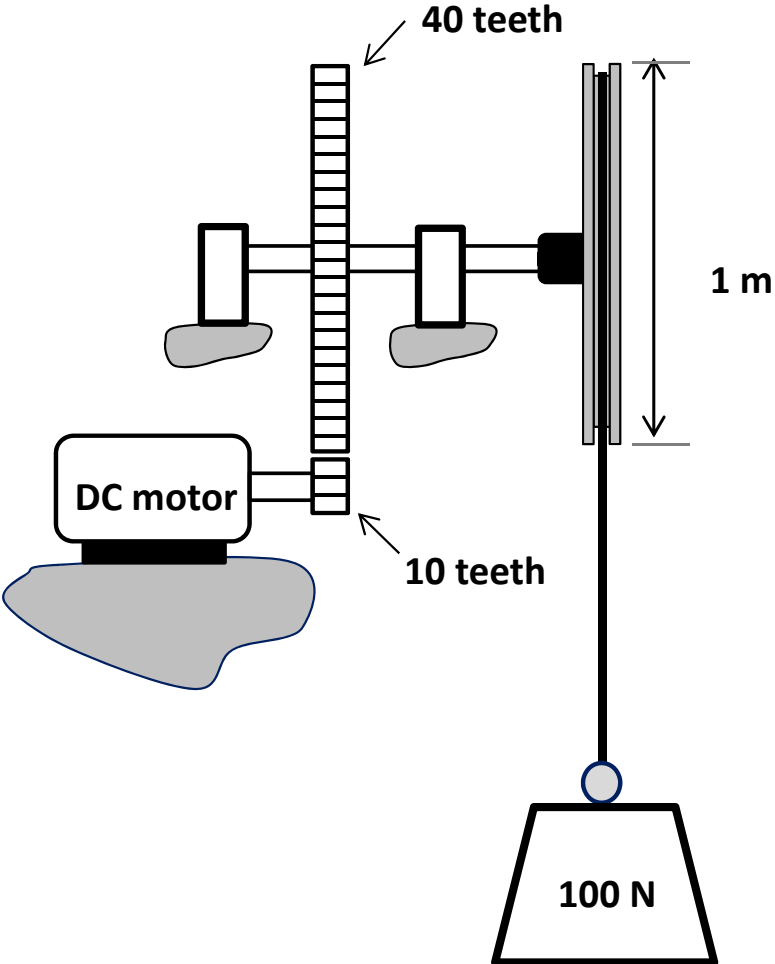

Problem 24

(5 points) The resultant force applied to beam ABC by the support at A is closest to:

- a. 1197 N
- b. 1286 N
- c. 1375 N
- d. 1464 N
- e. 1554 N
- f. 1642 N
- g. 1731 N
- h. 1820 N
- i. 1909 N

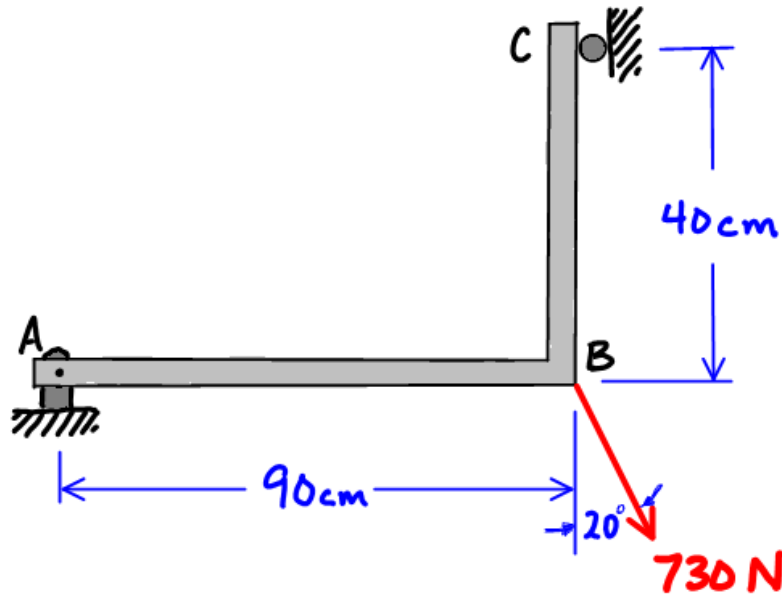

Problem 25

If the fan (output) is spinning at 300 RPM, then the rate of rotation of the DC motor must be closest to ...

- a. 55 RPM
- b. 110 RPM
- c. 155 RPM
- d. 165 RPM
- e. 200 RPM
- f. 250 RPM
- g. 550 RPM
- h. 1550 RPM
- i. 1600 RPM
- j. 1650 RPM

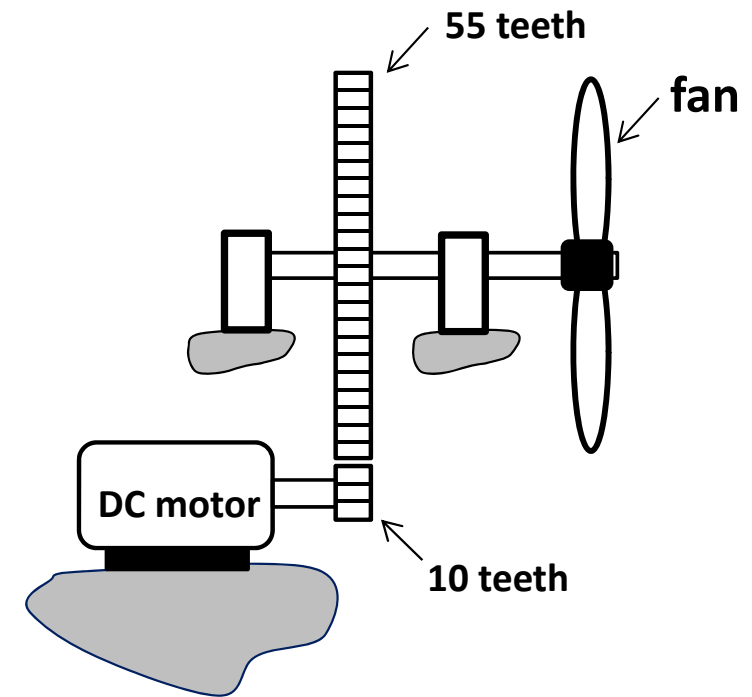

Problem 26

(5 points) The force carried by a hydraulic ram can be measured by measuring the hydraulic pressure in the ram and multiplying by the area of the piston head. Assuming there is no friction in the ram or in the pins, the force measured in the ram is closest to:

- a. 8.1 kN
- b. 8.7 kN
- c. 9.3 kN
- d. 10.0 kN
- e. 10.6 kN
- f. 11.2 kN
- g. 11.9 kN
- h. 12.5 kN
- i. 13.1 kN

