

II. FLUID STATICS

From a force analysis on a triangular fluid element at rest, the following three concepts are easily developed:

For a **continuous, hydrostatic, shear free** fluid:

1. Pressure is **constant** along a **horizontal plane**,
2. Pressure at a point is **independent of orientation**,
3. **Pressure change in any direction is proportional to the fluid density, local g, and vertical change in depth.**

These concepts are key to the solution of problems in fluid statics and lead to the following:

1. Two points at the same depth in a static fluid have the same pressure.
2. The orientation of a surface has no bearing on the pressure at a point in a static fluid.
3. Vertical depth is a key dimension in determining pressure change in a static fluid.

If we were to conduct a more general force analysis on a fluid in motion with constant density and viscosity, we would obtain the following:

$$\bar{\nabla} P = \rho \{ \bar{g} - \bar{a} \} + \mu \nabla^2 \bar{V}$$

Thus the pressure change in fluid in general depends on:

effects of fluid statics (ρg), Ch. II

inertial effects (ρa), Ch. III

viscous effects ($\mu \nabla^2 V$) Chs VI & VII

Note: For problems involving the effects of both (1) fluid statics and (2) inertial effects, it is the net $\bar{g} - \bar{a}$ acceleration vector that controls both the magnitude and direction of the pressure gradient.

This equation can be simplified for a fluid at rest (ie., no inertial or viscous effects) to yield:

$$\bar{\nabla} p = \rho \bar{g}$$

$$\frac{\partial p}{\partial x} = 0; \quad \frac{\partial p}{\partial y} = 0; \quad \frac{\partial p}{\partial z} = \frac{dp}{dz} = -\rho g$$

$$P_2 - P_1 = -\int_1^2 \rho g dz$$

It is appropriate at this point to review the differences between absolute, gage, and vacuum pressure. These differences are illustrated in Fig. 2.3 (shown below) and are based on the following definitions:

- absolute pressure - Pressure measured relative to absolute zero.
- gage pressure - Pressure $>$ P_{atm} measured relative to P_{atm}
- vacuum pressure - Pressure $<$ P_{atm} measured relative to P_{atm}
- P_{atm} - local absolute pressure due to the local atmosphere only.
standard P_{atm} at sea level = 1 atm = 101.3 kPa = 2116 lbf/ft²

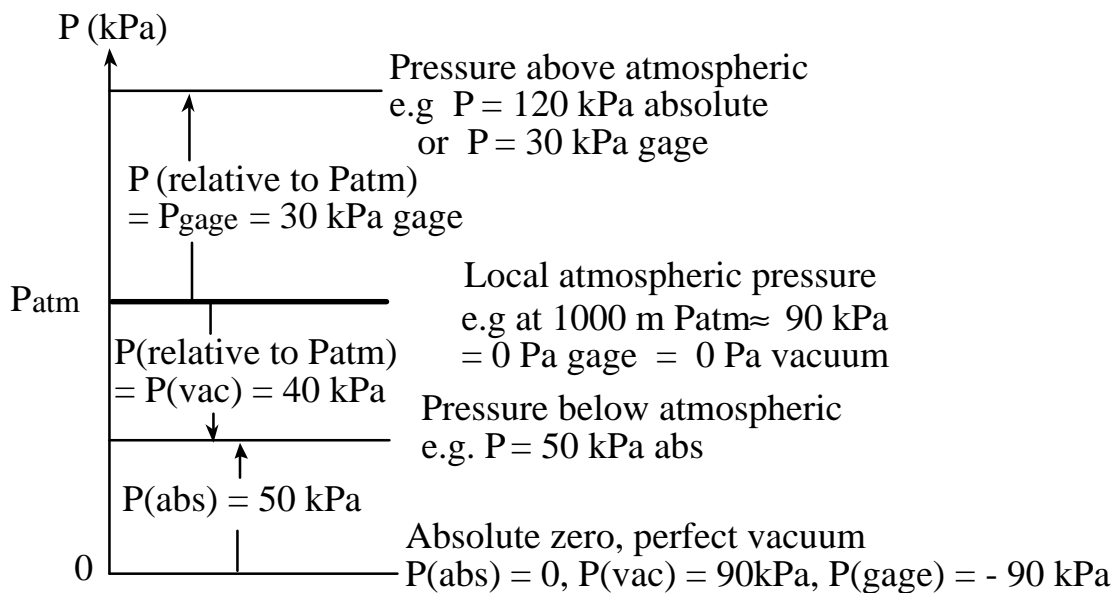

Fig. 2.3 Illustration of absolute, gage, and vacuum pressure

Hydrostatic Pressure in Liquids

For liquids and incompressible fluids, the previous integral expression for $P_2 - P_1$ integrates to

$$P_1 - P_2 = -\rho g (Z_2 - Z_1)$$

Note:

$Z_2 - Z_1$ is positive for Z_2 above Z_1 .

but

$P_2 - P_1$ is negative for Z_2 above Z_1 .

We can now define a new fluid parameter:

$\gamma = \rho g \equiv$ specific weight of the fluid

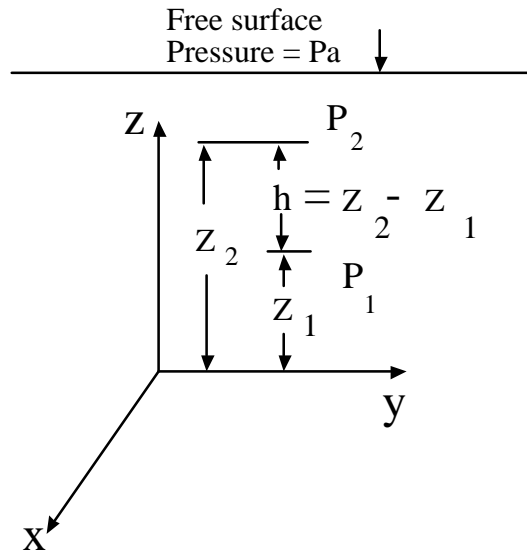

With this, the previous equation becomes (for an incompressible, static fluid)

$$P_2 - P_1 = -\gamma (Z_2 - Z_1)$$

The most common application of this result is that of **manometry**.

Consider the U-tube, multi-fluid manometer shown on the right.

If we first label all intermediate points between A & a, we can write for the overall pressure change

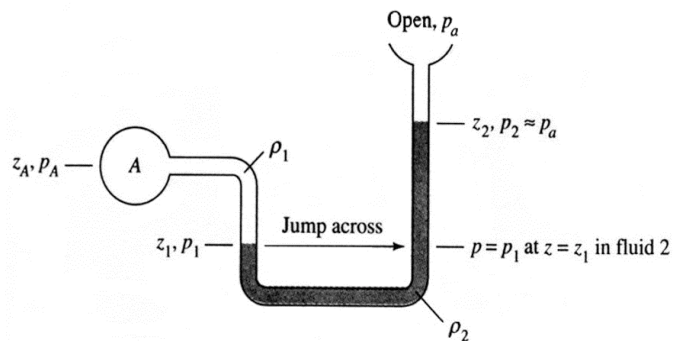

$$P_A - P_a = (P_A - P_1) + (P_1 - P_2) + (P_2 - P_a)$$

This equation was obtained by adding and subtracting each intermediate pressure. The total pressure difference is now expressed in terms of a series of intermediate pressure differences. Substituting the previous result for static pressure difference, we obtain

$$P_A - P_B = -\rho g(Z_A - Z_1) - \rho g(Z_1 - Z_2) - \rho g(Z_2 - Z_B)$$

Again note: Z positive up and $Z_A > Z_1$, $Z_1 < Z_2$, $Z_2 < Z_B$.

In general, follow the following steps when analyzing manometry problems:

1. On the manometer schematic, label points on each end of the manometer and at each intermediate point where there is a fluid-fluid interface, e.g. A - 1 - 2 - B.
2. Express the overall pressure difference in terms of appropriate intermediate pressure differences.

$$P_A - P_B = (P_A - P_1) + (P_1 - P_2) + (P_2 - P_B)$$

3. Express each intermediate pressure difference in terms of an appropriate product of specific weight (or ρg) * elevations change (and watch the signs).

$$P_A - P_B = -\gamma(Z_A - z_1) + -\gamma(z_1 - z_2) + -\gamma(z_2 - z_B)$$

When developing a solution for manometer problems, take care to:

1. Include all pressure changes.
2. Use correct ΔZ and γ with each fluid.
3. Use correct signs with ΔZ . If pressure difference is expressed as $P_A - P_1$, the elevation change should be written as $Z_A - Z_1$.
4. Watch units.

Manometer Example:

Given the indicated manometer, determine the gage pressure at A. $P_a = 101.3 \text{ kPa}$. The fluid at A is Meriam red oil no. 3.

$$\rho g_w = 9790 \text{ N/m}^3$$

$$\rho g_A = \text{S.G.} \cdot \rho g_w = 0.83 \cdot 9790 \text{ N/m}^3$$

$$\rho g_A = 8126 \text{ N/m}^3$$

$$\rho g_{\text{air}} = 11.8 \text{ N/m}^3$$

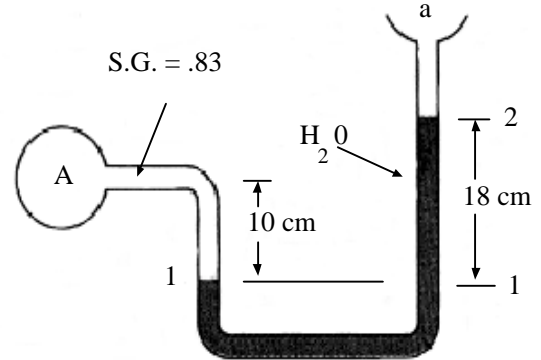

With the indicated points labeled on the manometer, we can write

$$P_A - P_a = P_A (\text{gage}) = (P_A - P_1) + (P_1 - P_2) + (P_2 - P_a)$$

Substituting the manometer expression for a static fluid, we obtain

$$P_A (\text{gage}) = -\rho g_A (z_A - z_1) - \rho g_w (z_1 - z_2) - \rho g_a (z_2 - z_a)$$

Neglect the contribution due to the air column. Substituting values, we obtain

$$P_A (\text{gage}) = -8126 \text{ N/m}^3 \cdot 0.10 \text{ m} - 9790 \text{ N/m}^3 \cdot -0.18 = \underline{949.6 \text{ N/m}^2} \text{ Ans}$$

Note why: $(z_A - z_1) = 0.10 \text{ m}$ and $(z_1 - z_2) = -0.18 \text{ m}$, & we did not use P_a

Review the text examples for manometry.

See Table 2.1 for values of specific weight, γ , in both B.G. and S.I. units.

Hydrostatic Pressure in Gases

Since gases are compressible, density is a non-constant variable in the previous expression for dP/dz . Assuming the gas is an ideal gas, we can write

$$\frac{dP}{dz} = -\rho g = -\frac{P}{RT}g \quad \text{or} \quad \int_1^2 \frac{dP}{P} = \ln \frac{P_2}{P_1} = -\frac{g}{R} \int_1^2 \frac{dz}{T}$$

For an isothermal atmosphere with $T = T_o$, this integrates to

$$P_2 = P_1 \exp\left[-\frac{g(z_2 - z_1)}{RT_o}\right]$$

Up to an altitude of approximately 36,000ft (11,000 m), the mean atmospheric temperature decreases nearly linearly and can be represented by

$$T \approx T_o - Bz \quad \text{where } B \text{ is the lapse rate}$$

The following values are assumed to apply for air from sea level to 36,000 ft:

$$T_o = 518.69^\circ\text{R} = 288.16^\circ\text{K} \quad (15^\circ\text{C})$$

$$B = 0.003566^\circ\text{R}/\text{ft} = 0.650^\circ\text{K}/\text{m}$$

Substituting the linear temperature variation into the previous equation and integrating we obtain

$$P = P_a \left(1 - \frac{Bz}{T_o}\right)^{g/(RB)} \quad \text{where } \frac{g}{RB} = 5.26 \text{ (for air)}$$

$$\text{and } R = 287 \text{ m}^2/(\text{s}^2 \cdot \text{K})$$

Review example 2.2 in the text.

Hydrostatic Forces on Plane Surfaces

Consider a plane surface of arbitrary shape and orientation, submerged in a static fluid as shown:

If P represents the local pressure at any point on the surface and h the depth of fluid above any point on the surface, from basic physics we can easily show that

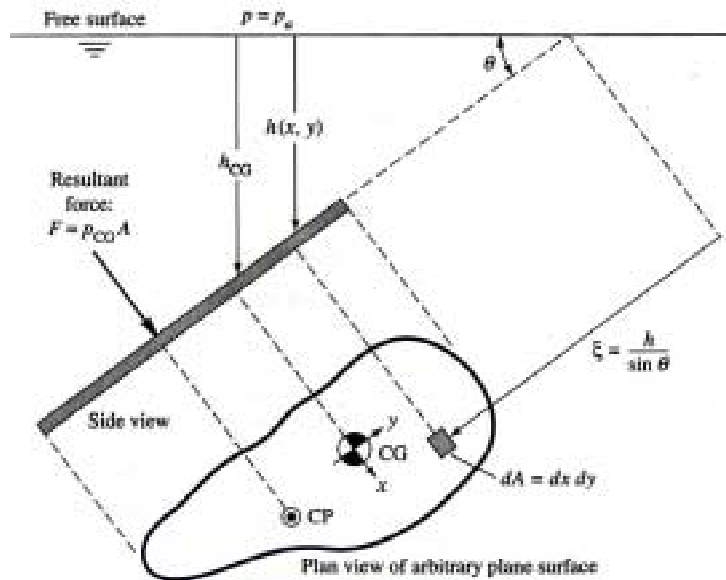

the net hydrostatic force on a plane surface is given by (see text for development):

$$F = \int_A P dA = P_{cg} A$$

Thus, basic physics says that the hydrostatic force is a distributed load equal to the integral of the local pressure force over the area. This is equivalent to the following:

The hydrostatic force on one side of a plane surface submerged in a static fluid equals the product of the fluid pressure at the centroid of the surface times the surface area in contact with the fluid.

Also: Since pressure acts normal to a surface, the direction of the resultant force will always be **normal to the surface**.

Note: In most cases, since it is the net hydrostatic force that is desired and the contribution of atmospheric pressure P_a will act on both sides of a surface, the result of atmospheric pressure P_a will cancel and the net force is obtained by

$$F = \rho g h_{cg} A$$

$$F = P_{cg} A$$

P_{cg} is now the **gage pressure** at the centroid of the area in contact with the fluid.

Therefore, to obtain the net hydrostatic force F on a plane surface:

1. Determine depth of centroid h_{cg} for the area in contact with the fluid.
2. Determine the (gage) pressure at the centroid P_{cg} .
3. Calculate $F = P_{cg}A$.

The following page shows the centroid, and other geometric properties of several common areas.

It is noted that care must be taken when dealing with layered fluids. The procedure essentially requires that the force on the part of the plane area in each individual layer of fluid must be determined separately for each layer using the steps listed above.

We must now determine the effective point of application of F . This is commonly called the “**center of pressure - cp**” of the hydrostatic force.

Note: This is not necessarily the same as the c.g.

Define an $x - y$ coordinate system whose origin is at the centroid, c.g, of the area.

The location of the resultant force is determined by integrating the moment of the distributed fluid load on the surface about each axis and equating this to the moment of the resultant force about that axis. Therefore, for the moment about the x axis:

$$F y_{cp} = \int_A y P dA$$

Applying a procedure similar to that used previously to determine the resultant force, and using the definition (see text for detailed development), we obtain

$$Y_{cp} = -\frac{\rho g \sin \theta I_{xx}}{P_{cg} A} \leq 0$$

where: I_{xx} is defined as the Moment of Inertia, or

the $\int y^2 dA$ 2nd moment of the area

Therefore, the resultant force will always act at a distance y_{cp} **below** the centroid of the surface (except for the special case of $\sin \theta = 0$).

PROPERTIES OF PLANE SECTIONS

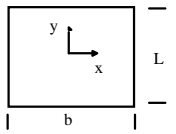
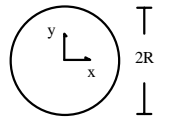
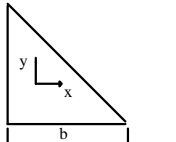
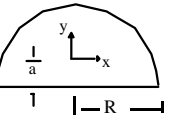
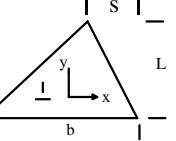
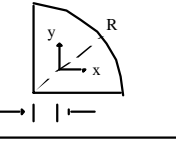
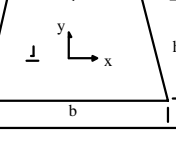
Geometry	Centroid	Moment of Inertia I_{xx}	Product of Inertia I_{xy}	Area
	$b/2, L/2$	$\frac{bL^3}{12}$	0	$b \cdot L$
	0,0	$\frac{\pi R^4}{4}$	0	πR^2
	$b/3, L/3$	$\frac{bL^3}{36}$	$-\frac{b^2L^2}{72}$	$\frac{b \cdot L}{2}$
	$0, a = \frac{4R}{3\pi}$	$R^4 \left(\frac{\pi}{8} - \frac{8}{9\pi} \right)$	0	$\frac{\pi R^2}{2}$
	$a = \frac{L}{3}$	$\frac{bL^3}{36}$	$\frac{b(b-2s)L^2}{72}$	$\frac{1}{2} b \cdot L$
	$a = \frac{4R}{3\pi}$	$\left(\frac{\pi}{16} - \frac{4}{9\pi} \right) R^4$	$\left(\frac{1}{8} - \frac{4}{9\pi} \right) R^4$	$\frac{\pi R^2}{4}$
	$a = \frac{h(b+2b_1)}{3(b+b_1)}$	$\frac{h^3(b^2+4bb_1+b_1^2)}{36(b+b_1)}$	0	$(b+b_1) \frac{h}{2}$

Fluid Specific Weight

	1bf/ft ³	N/m ³		1bf/ft ³	N/m ³
Air	.0752	11.8	Seawater	64.0	10,050
Oil	57.3	8,996	Glycerin	78.7	12,360
Water	62.4	9,790	Mercury	846.	133,100
Ethyl	49.2	7,733	Carbon	99.1	15,570

Proceeding in a similar manner for the x location, and defining I_{xy} = product of inertia, we obtain

$$X_{cp} = -\frac{\rho g \sin\theta I_{xy}}{P_{cg} A}$$

where X_{cp} can be either positive or negative since I_{xy} can be either positive or negative.

Note: For areas with a vertical plane of symmetry through the centroid, i.e. the y - axis (e.g. squares, circles, isosceles triangles, etc.), the center of pressure is located directly below the centroid along the plane of symmetry, i.e., $X_{cp} = 0$.

Key Points: The values X_{cp} and Y_{cp} are both measured with respect to the centroid of the area in contact with the fluid.

X_{cp} and Y_{cp} are both measured in the inclined plane of the area;

i.e., Y_{cp} is not necessarily a vertical dimension, unless $\theta = 90^\circ$.

Special Case: For most problems where (1) we have a single, homogeneous fluid (i.e. not applicable to layers of multiple fluids) and (2) the surface pressure is atmospheric, the fluid specific weight γ cancels in the equation for Y_{cp} and X_{cp} and we have the following simplified expressions:

$$F = \rho g h_{cg} A$$

$$Y_{cp} = -\frac{I_{xx} \sin\theta}{h_{cg} A} \quad X_{cp} = -\frac{I_{xy} \sin\theta}{h_{cg} A}$$

However, for problems where we have either (1) multiple fluid layers, or (2) a container with surface pressurization $> P_{atm}$, these simplifications do not occur and **the original, basic expressions** for F , Y_{cp} , and X_{cp} **must be used**; i.e., take

care to use the approximate expressions only for cases where they apply. The basic equations always work.

Summary:

1. The resultant force is determined from the product of the pressure at the centroid of the surface times the area in contact with the fluid.
2. The centroid is used to determine the magnitude of the force. This is **not the location** of the resultant force.
3. The location of the resultant force will be at the center of pressure which will be at a location **Y_{cp} below the centroid** and **X_{cp}** as specified previously.
4. **$X_{cp} = 0$** for areas with a vertical plane of symmetry through the c.g.

Example 2.5

Given: Gate, 5 ft wide
Hinged at B
Holds seawater as shown

Find:

- a. Net hydrostatic force on gate
- b. Horizontal force at wall - A
- c. Hinge reactions - B

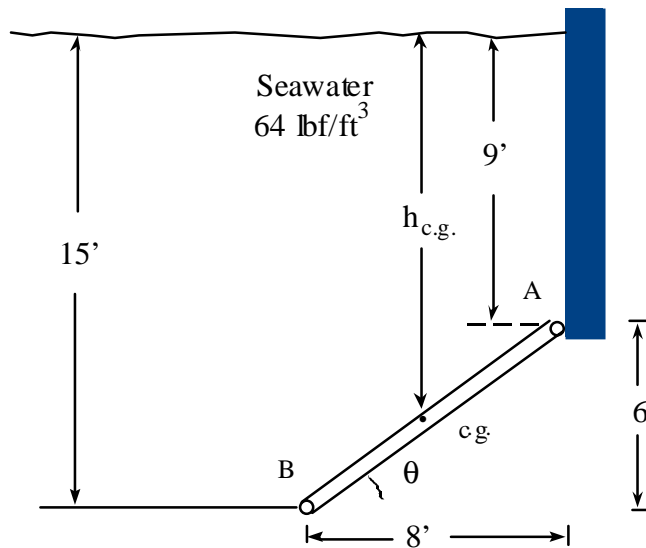

a. By geometry: $\theta = \tan^{-1} (6/8) = 36.87^\circ$ Neglect P_{atm}

Since the plate is rectangular, $h_{c.g.} = 9 \text{ ft} + 3 \text{ ft} = 12 \text{ ft}$ $A = 10 \times 5 = 50 \text{ ft}^2$

$P_{c.g.} = \gamma h_{c.g.} = 64 \text{ lbf/ft}^3 * 12 \text{ ft} = 768 \text{ lbf/ft}^2$

$\therefore F_p = P_{c.g.} A = 768 \text{ lbf/ft}^2 * 50 \text{ ft}^2 = \underline{38,400 \text{ lbf}}$

b. Horizontal Reaction at A

Must first find the location, c.p., for F_p

$$y_{cp} = -\rho g \sin \theta \frac{I_{xx}}{P_{cg} A} = -\frac{I_{xx} \sin \theta}{h_{cg} A}$$

For a rectangular wall:

$$I_{xx} = bh^3/12$$

$$I_{xx} = 5 * 10^3/12 = 417 \text{ ft}^4$$

Note: The relevant area is a rectangle, not a triangle.

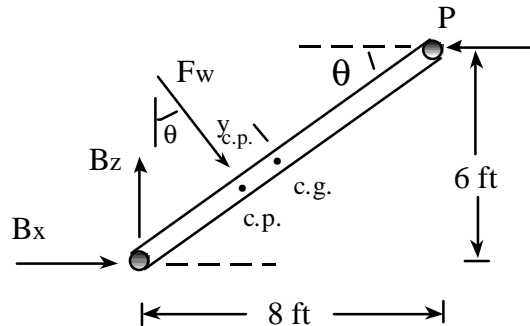

Note: Do not overlook the hinged reactions at B.

$$y_{cp} = -\frac{417 \text{ ft}^4 \cdot 0.6}{12 \text{ ft} \cdot 50 \text{ ft}^2} = -0.417 \text{ ft} \quad \text{below c.g.}$$

$x_{cp} = 0$ due to symmetry

$$\Sigma M_B = 0$$

$$(5 - 0.417) \cdot 38,400 - 6P = 0$$

$$\underline{P = 29,330 \text{ lbf}} \quad \leftarrow$$

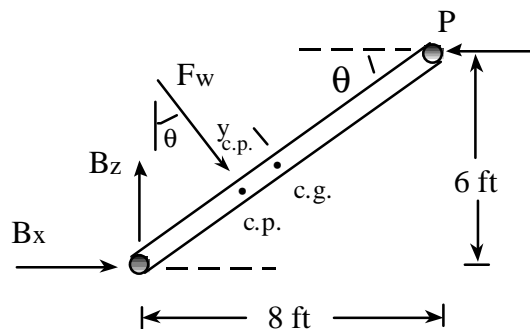

$$c. \quad \sum F_x = 0, \quad B_x + F \sin \theta - P = 0$$

$$B_x + 38,400 * 0.6 - 29,330 = 0$$

$$B_x = \underline{6290 \text{ lbf}} \quad \rightarrow$$

$$\sum F_z = 0, \quad B_z - F \cos \theta = 0$$

$$B_z = 38,400 * 0.8 = \underline{30,720 \text{ lbf}} \quad \uparrow$$

Note: Show the direction of all forces in final answers.

Summary: To find net hydrostatic force on a plane surface:

- 1. Find area in contact with fluid.**
- 2. Locate centroid of that area.**
- 3. Find hydrostatic pressure P_{cg} at centroid, typically $= \gamma h_{cg}$ (generally neglect P_{atm}).**
- 4. Find force $F = P_{cg} A$.**
- 5. The location will not be at the c.g., but at a distance y_{cp} below the centroid. y_{cp} is in the plane of the area.**

Plane Surfaces in Layered Fluids

For plane surfaces in layered fluids, the part of the surface in each fluid layer must essentially be worked as a separate problem. That is, for each layer:

- 1.) Identify the area of the plate in contact with each layer,
- 2.) Locate the c.g. for the part of the plate in each layer and the pressure at the c.g., and
3. Calculate the force on each layered element using $F_1 = P_c \cdot g_1 \cdot A_1$.

Repeat for each layer.

Use the usual procedure for finding the location of the force for each layer.

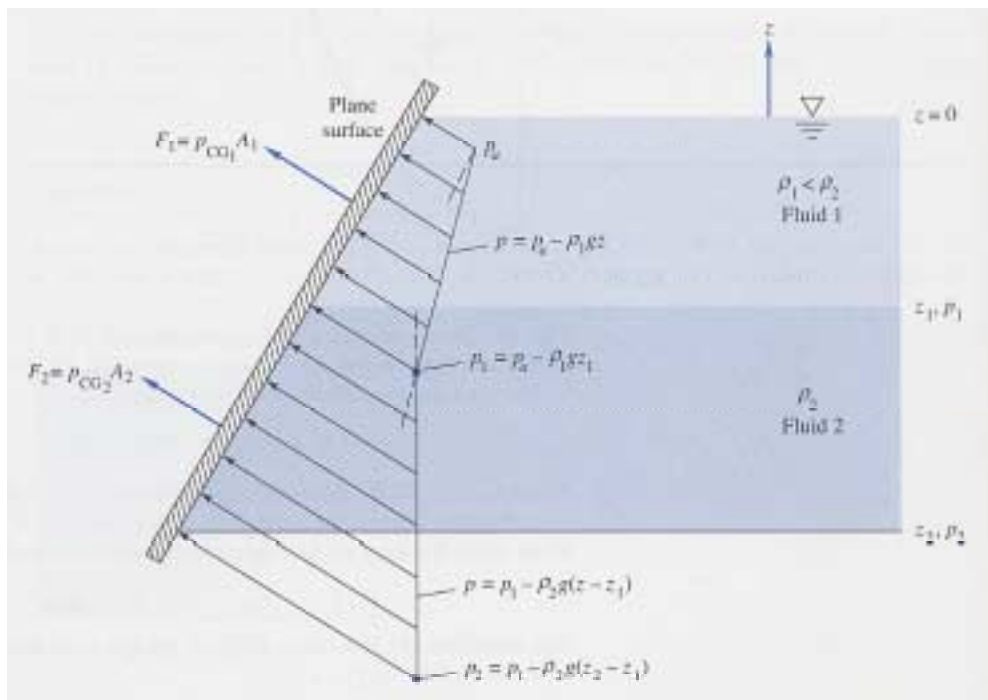

Review all text examples for forces on plane surfaces.

Forces on Curved Surfaces

Since this class of surface is curved, the direction of the force is different at each location on the surface.

Therefore, we will evaluate the x and y components of net hydrostatic force separately.

Consider curved surface, a-b. Force balances in x & y directions yield

$$F_h = F_H$$

$$F_v = W_{\text{air}} + W_1 + W_2$$

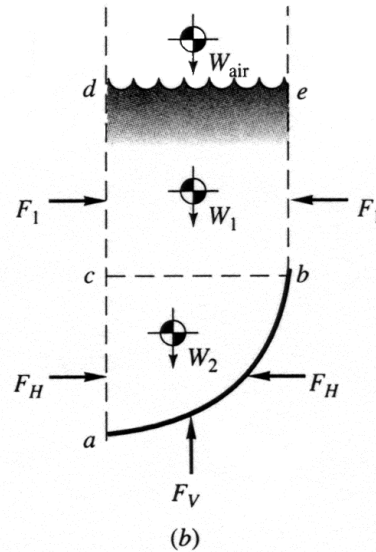

From this force balance, the basic rules for determining the horizontal and vertical component of forces on a curved surface in a static fluid can be summarized as follows:

Horizontal Component, F_h

The **horizontal** component of force on a curved surface equals the force on the plane area formed by the **projection of the curved surface** onto a **vertical plane** normal to the component.

The horizontal force will act through the c.p. (**not the centroid**) of the projected area.

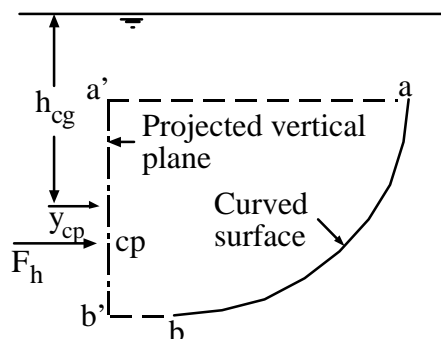

Therefore, to determine the horizontal component of force on a curved surface in a hydrostatic fluid:

1. Project the curved surface into the appropriate vertical plane.
2. Perform all further calculations on the vertical plane.
3. Determine the location of the centroid - c.g. of the vertical plane.
4. Determine the depth of the centroid - h_{cg} of the vertical plane.
5. Determine the pressure - $P_{cg} = \rho g h_{cg}$ at the centroid of the vertical plane.
6. Calculate $F_h = P_{cg} A$, where **A is the area of** the projection of the curved surface into the vertical plane, ie. **the area of the vertical plane**.
7. The location of F_h is through the center of pressure of the vertical plane, not the centroid.

Get the picture? All elements of the analysis are performed with the vertical plane. The original curved surface is important only as it is used to define the projected vertical plane.

Vertical Component - F_v

The **vertical** component of force on a curved surface equals the **weight** of the **effective** column of fluid **necessary to cause the pressure on the surface**.

The use of the words **effective column of fluid** is important in that there may not always actually be fluid directly above the surface. (See graphic that follows.)

This effective column of fluid is specified by identifying the column of fluid that would be required to cause the pressure at each location on the surface.

Thus, to identify the effective volume - V_{eff} :

1. Identify the curved surface in contact with the fluid.
2. Identify the pressure at each point on the curved surface.
3. Identify the height of fluid required to develop the pressure.

4. These collective heights combine to form V_{eff} .

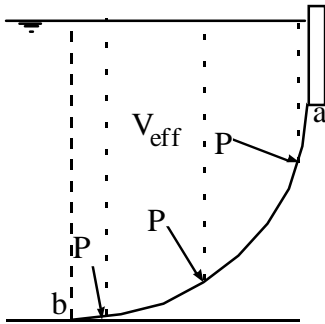

Fluid above the surface

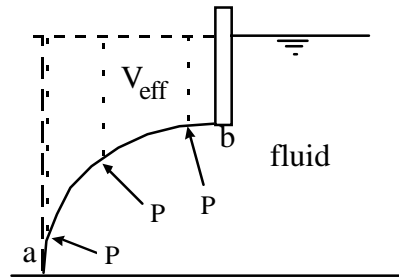

No fluid actually above surface

These two examples show two typical cases where this concept is used to determine V_{eff} .

The vertical force acts **vertically** through the centroid (center of mass) of the effective column of fluid. The vertical direction will be the direction of the vertical components of the pressure forces.

Therefore, to determine the vertical component of force on a curved surface in a hydrostatic fluid:

1. Identify the effective column of fluid necessary to cause the fluid pressure on the surface.
2. Determine the volume of the effective column of fluid.
3. Calculate the weight of the effective column of fluid - $F_V = \rho g V_{\text{eff}}$.
4. The location of F_V is through the centroid of V_{eff} .

Finding the Location of the Centroid

A second problem associated with the topic of curved surfaces is that of finding the location of the centroid of V_{eff} .

Recall:

Centroid = the location where a point area, volume, or mass can be placed to yield the same first moment of the distributed area, volume, or mass, e.g.

$$x_{cg}V_1 = \int_V x dV$$

This principle can also be used to determine the location of the centroid of complex geometries.

For example:

If $V_{eff} = V_1 + V_2$

then

$$x_{cg}V_{eff} = x_1V_1 + x_2V_2$$

or for the second geometry

$$V_T = V_1 + V_{eff}$$

$$x_T V_T = x_1 V_1 + x_{cg} V_{eff}$$

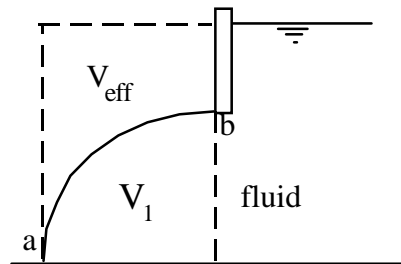
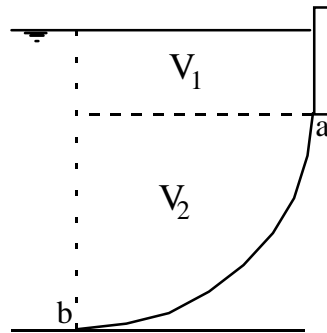

Note: In the figures shown above, each of the x values would be specified relative to a vertical axis through b since the cg of the quarter circle is most easily specified relative to this axis.

Example:

Gate AB holds back 15 ft of water. Neglecting the weight of the gate, determine the magnitude (per unit width) and location of the hydrostatic forces on the gate and the resisting moment about B.

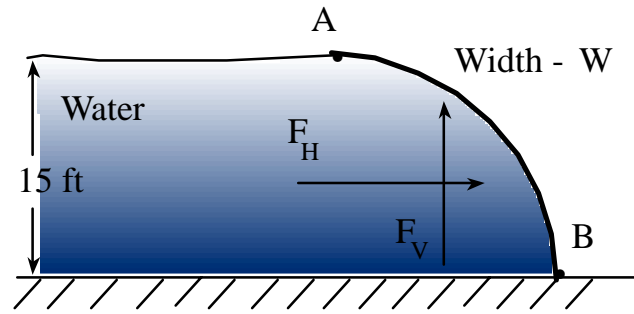

a. Horizontal component

$$\gamma = \rho g = 62.4 \text{ lbf/ft}^3$$

Rule: Project the curved surface into the vertical plane. Locate the centroid of the projected area. Find the pressure at the centroid of the vertical projection.
 $F = P_{cg} A_p$

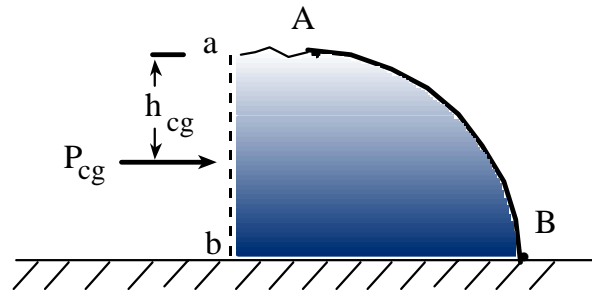

Note: All calculations are done with the projected area. The curved surface is not used at all in the analysis.

The curved surface projects onto plane a - b and results in a **rectangle**, (not a quarter circle) 15 ft x W. For this rectangle:

$$h_{cg} = 7.5, \quad P_{cg} = \gamma h_{cg} = 62.4 \text{ lbf/ft}^3 * 7.5 \text{ ft} = 468 \text{ lbf/ft}^2$$

$$F_h = P_{cg} A = 468 \text{ lbf/ft}^2 * 15 \text{ ft} * W = \underline{7020 W \text{ lbf}} \text{ per ft of width} \quad \longrightarrow$$

$$\text{Location: } I_{xx} = bh^3/12 = W * 15^3 /12 = 281.25 W \text{ ft}^4$$

$$y_{cp} = -\frac{I_{xx} \sin \theta}{h_{cg} A} = -\frac{281.25 W \text{ ft}^4 \sin 90^\circ}{7.5 \text{ ft} * 15 W \text{ ft}^2} = -2.5 \text{ ft}$$

The location is 2.5 ft below the c.g. or 10 ft below the surface, 5 ft above the bottom.

b. Vertical force:

Rule: F_v equals the weight of the effective column of fluid above the curved surface (shown by the dashed diagonal lines).

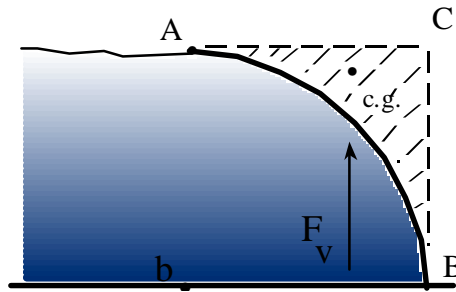

Q: What is the effective volume of fluid above the surface?

What volume of fluid would result in the actual pressure distribution on the curved surface?

$$\text{Vol} = \text{Vol}_{A-B-C}$$

$$V_{\text{rec}} = V_{\text{qc}} + V_{\text{ABC}},$$

$$V_{\text{ABC}} = V_{\text{rec}} - V_{\text{qc}}$$

$$V_{\text{ABC}} = V_{\text{eff}} = 15^2 W - \pi 15^2/4 * W = 48.29 W \text{ ft}^3$$

$$F_v = \rho g V_{\text{eff}} = 62.4 \text{ lbf/ft}^3 * 48.29 \text{ ft}^3 = \underline{3013 \text{ lbf per ft of width}}$$



Note: F_v is directed upward even though the effective volume is above the surface.

c. What is the location?

Rule: F_v will act through the centroid of the effective volume causing the force.

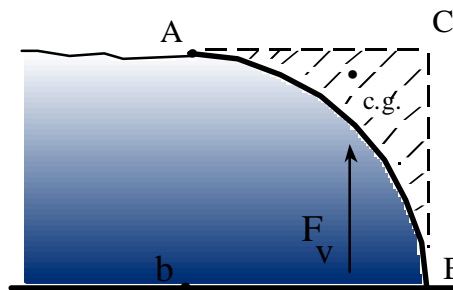

We need the centroid of volume A-B-C. How do we obtain this centroid?

Use the concept which is the basis of the centroid, the “first moment of an area.”

$$\text{Since: } A_{\text{rec}} = A_{\text{qc}} + A_{\text{ABC}} \quad M_{\text{rec}} = M_{\text{qc}} + M_{\text{ABC}} \quad M_{\text{ABC}} = M_{\text{rec}} - M_{\text{qc}}$$

Note: We are taking moments about the left side of the figure, ie., point b. **WHY?**

(The c.g. of the quarter circle is known to be at $4R/3\pi$ w.r.t. b.)

$$x_{cg} A = x_{rec} A_{rec} - x_{qc} A_{qc}$$

$$x_{cg} \{15^2 - \pi \cdot 15^2/4\} = 7.5 \cdot 15^2 - \{4 \cdot 15/3/\pi\} \cdot \pi \cdot 15^2/4$$

$$x_{cg} = 11.65 \text{ ft} \quad \{ \text{distance to rt. of b to the centroid} \}$$

Q: Do we need a y location? Why?

d. Calculate the moment about B needed for equilibrium.

$$\sum M_B = 0 \quad \text{clockwise positive.}$$

$$M_B + 5 F_h + (15 - x_v) F_v = 0$$

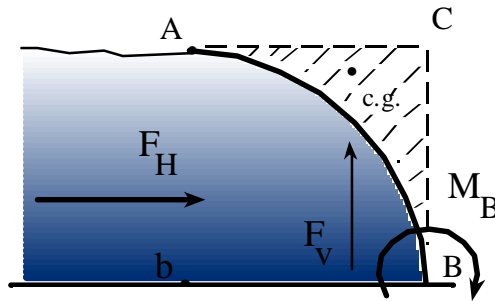

$$M_B + 5 \cdot 7020W + (15 - 11.65) \cdot 3013W = 0$$

$$M_B + 35,100W + 10,093.6W = 0$$

$$\underline{M_B = -45,194 W \text{ ft-lbf}} \quad \text{per unit width}$$

Why is the answer negative? (What did we assume for an initial direction of M_B ?)

The hydrostatic forces will tend to roll the surface clockwise relative to B, thus a resisting moment that is counterclockwise is needed for static equilibrium.

Always review your answer (all aspects: magnitude, direction, units, etc.) to determine if it makes sense relative to physically what you understand about the problem. Begin to think like an engineer.

Buoyancy

An important extension of the procedure for vertical forces on curved surfaces is that of the concept of buoyancy.

The basic principle was discovered by Archimedes.

It can be easily shown that (see text for detailed development) the buoyant force F_b is given by:

$$F_b = \rho g V_b$$

where V_b is the volume of the fluid displaced by the submerged body and ρg is the specific weight of the fluid displaced.

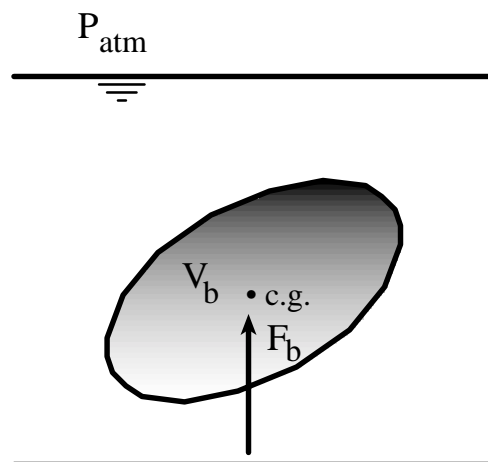

Thus, the **buoyant force** equals the **weight of the fluid displaced**, which is equal to the product of the specific weight times the volume of fluid displaced.

The location of the buoyant force is through a vertical line of action, directed upward, which acts through the centroid of the volume of fluid displaced.

Review all text examples and material on buoyancy.

Pressure Distribution in Rigid Body Motion

All of the problems considered to this point were for static fluids. We will now consider an extension of our static fluid analysis to the case of rigid body motion, where the entire fluid mass moves and accelerates uniformly (as a rigid body).

The container of fluid shown below is accelerated uniformly up and to the right as shown.

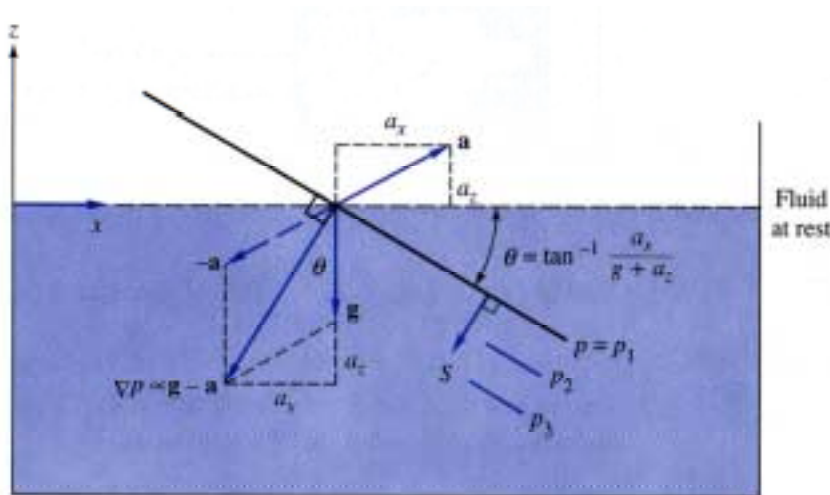

From a previous analysis, the general equation governing fluid motion is

$$\bar{\nabla} P = \rho(\bar{\mathbf{g}} - \bar{\mathbf{a}}) + \mu \nabla^2 \bar{\mathbf{V}}$$

For rigid body motion, there is no velocity gradient in the fluid, therefore

$$\mu \nabla^2 \bar{\mathbf{V}} = 0$$

The simplified equation can now be written as

$$\bar{\nabla} P = \rho(\bar{\mathbf{g}} - \bar{\mathbf{a}}) = \rho \bar{\mathbf{G}}$$

where $\bar{\mathbf{G}} = \bar{\mathbf{g}} - \bar{\mathbf{a}} \equiv$ the net acceleration vector acting on the fluid.

This result is similar to the equation for the variation of pressure in a hydrostatic fluid.

However, in the case of rigid body motion:

- * $\bar{\nabla}P = f$ { fluid density & the **net** acceleration vector- $\bar{G} = \bar{g} - \bar{a}$ }
- * $\bar{\nabla}P$ acts in the vector direction of $\bar{G} = \bar{g} - \bar{a}$.
- * Lines of constant pressure are perpendicular to \bar{G} . The new orientation of the free surface will also be perpendicular to \bar{G} .

The equations governing the analysis for this class of problems are most easily developed from an acceleration diagram.

Acceleration diagram:

For the indicated geometry:

$$\theta = \tan^{-1} \left\{ \frac{a_x}{g + a_z} \right\}$$

$$\frac{dP}{ds} = \rho G \quad \text{where } G = \left\{ a_x^2 + (g + a_z)^2 \right\}^{1/2}$$

$$\text{and } P_2 - P_1 = \rho G (s_2 - s_1)$$

Note: $P_2 - P_1 \neq \rho g (z_2 - z_1)$

and

$s_2 - s_1$ is not a vertical dimension

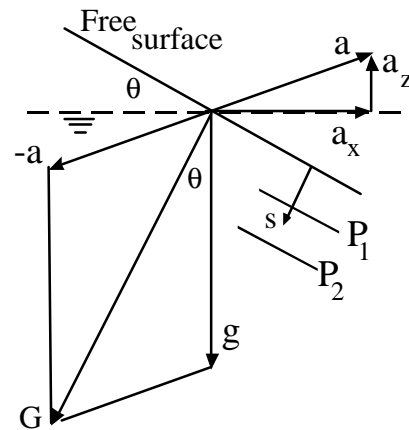

Note: s is the depth to a given point **perpendicular** to the free surface or **its extension**. s is aligned with \bar{G} .

In analyzing typical problems with rigid body motion:

1. Draw the acceleration diagram taking care to correctly indicate $-a$, g , and θ , the inclination angle of the free surface.
2. Using the previously developed equations, solve for G and θ .
3. If required, use geometry to determine $s_2 - s_1$ (the perpendicular distance from the free surface to a given point) and then the pressure at that point relative to the surface using $P_2 - P_1 = \rho G (s_2 - s_1)$.

Key Point: Do not use ρg to calculate $P_2 - P_1$, use ρG .

Example 2.12

Given: A coffee mug, 6 cm x 6 cm square, 10 cm deep, contains 7 cm of coffee. The mug is accelerated to the right with $a_x = 7 \text{ m/s}^2$. Assuming rigid body motion and $\rho_c = 1010 \text{ kg/m}^3$,

Determine: a. Will the coffee spill?

b. P_g at "a & b".

c. F_{net} on left wall.

a. First draw schematic showing the original orientation and final orientation of the free surface.

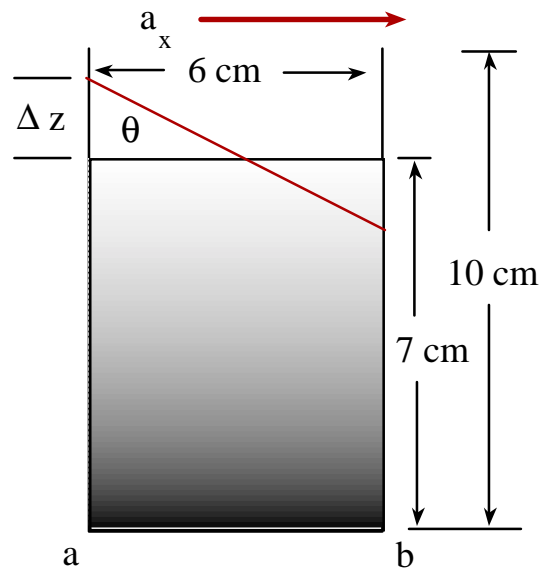

$$\rho_c = 1010 \text{ kg/m}^3 \quad a_x = 7 \text{ m/s}^2 \quad a_z = 0 \quad g = 9.8907 \text{ m/s}^2$$

We now have a new free surface at an angle θ where

$$\theta = \tan^{-1} \left\{ \frac{a_x}{g + a_z} \right\}$$

$$\theta = \tan^{-1} \frac{7}{9.807} = 35.5^\circ$$

$$\Delta z = 3 \tan 35.5 = 2.14 \text{ cm}$$

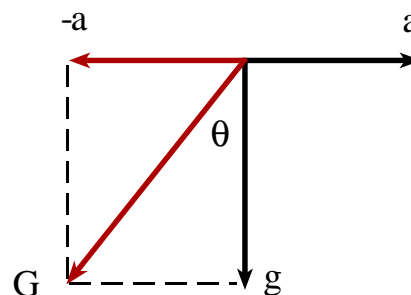

$$h_{\max} = 7 + 2.14 = 9.14 \text{ cm} < 10 \text{ cm} \therefore \text{Coffee will not spill.}$$

b. Pressure at “a & b.”

$$P_a = \rho G \Delta s_a$$

$$G = \{a_x^2 + g^2\}^{1/2} = \{7^2 + 9.807^2\}^{1/2}$$

$$G = 12.05 \text{ m/s}^2$$

$$\Delta s_a = \{7 + z\} \cos \theta$$

$$\Delta s_a = 9.14 \text{ cm} \cos 35.5 = 7.44 \text{ cm}$$

$$P_a = 1010 \text{ kg/m}^3 * 12.05 \text{ m/s}^2 * 0.0744 \text{ m}$$

$$P_a = 906 \text{ (kg m/s}^2\text{)/m}^2 = \underline{\mathbf{906 \text{ Pa}}}$$

Note: $P_a \neq \rho g y$ $G \neq g$

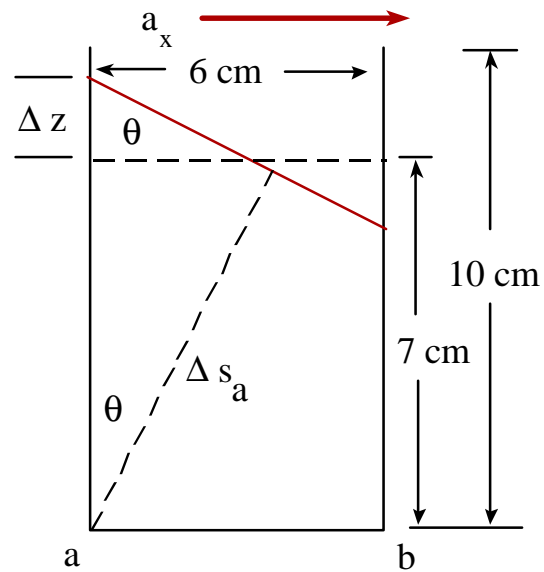

Q: How would you find the pressure at b, P_b ?

c. What is the force on the left wall?

We have a plane surface, what is the rule?

Find cg , P_{cg} , $F = P_{cg} \cdot A$

Vertical depth to cg is:

$$z_{cg} = 9.14/2 = 4.57 \text{ cm}$$

$$\Delta s_{cg} = 4.57 \cos 35.5 = 3.72 \text{ cm}$$

$$P_{cg} = \rho G \Delta s_{cg}$$

$$P_{cg} = 1010 \text{ kg/m}^3 * 12.05 \text{ m/s}^2 * 0.0372 \text{ m}$$

$$P_{cg} = 452.7 \text{ N/m}^2$$

$$F = P_{cg} A = 452.7 \text{ N/m}^2 * 0.0914 * 0.06 \text{ m}^2$$

$$\underline{\mathbf{F = 2.48 \text{ N} \leftarrow}}$$

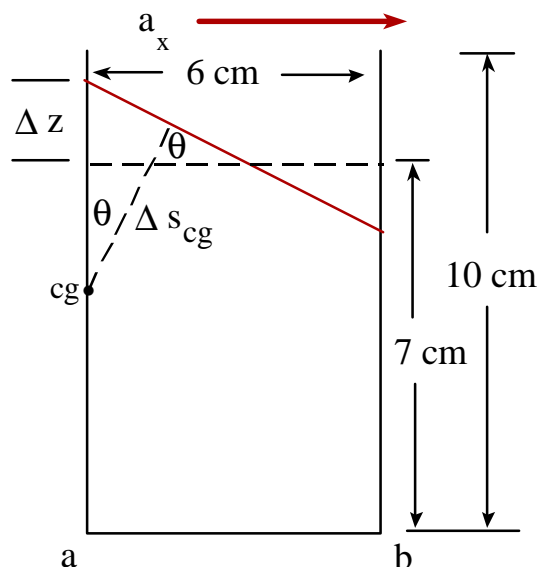

What is the direction?

Horizontal, perpendicular to the wall;

i.e. **Pressure always acts normal to a surface.**

Q: How would you find the force on the right wall?